

UDC 004.942

## THE DYNAMIC ANALYSIS OF THE MAIN CHARACTERISTICS OF ELECTROMAGNETIC LIFTING INSTALLATION ELEMENTS

A.A. Aikeyeva<sup>1</sup>, B.A. Zhautikov<sup>2</sup>, X.S. Rogovaya<sup>1</sup>, F.B. Zhautikov<sup>3</sup>, P.A. Mukhtarova<sup>4</sup>,  
A.R. Tanskozhanova<sup>1</sup>, A.E. Ospanov<sup>5</sup>

<sup>1</sup>The Karaganda State University the academician E.A. Buketov, Kazakhstan [aikeyeva@mail.ru](mailto:aikeyeva@mail.ru)

<sup>2</sup>The Atyrau State University named after Kh. Dosmukhamedov; Kazakhstan

<sup>3</sup>The Karaganda State Industrial University; Kazakhstan

<sup>4</sup>The Asian Pacific University of Innovations and Technologies, Malaysia;

<sup>5</sup>The Karaganda State Technical University. Kazakhstan

*This work concerns creation of imitating model of elements of the system "skip- constant magnet-coil" of electromagnetic lifting installation. In the work the principle of work of electromagnetic lifting installation elements is presented and described. For model operation the ANSYS Maxwell program was used. The problem of model operation is definition of the main magnetic characteristics of installation elements (Lorentz force, magnetic intensity and magnetic induction). The work describes five experiments which calculated parameters are used for construction the common graphic charts. By results of experiments engineering equations with one variable are worked-out. The received equations allow to define the characteristics of magnetic field counted in the work.*

**Keywords:** electromagnetic lifting installation, "skip-constant magnet-coil", ANSYS Maxwell, induction of magnetic field, the Lorentz force, magnetic intensity.

### Introduction

The imitation modeling procedure of interaction processes of the electromagnetic lifting installation elements protected by the innovative patent № 27177 "Electromagnetic lifting installation (options)" [1] pursues the purpose to determine optimum and rational parameters of system without expensive calculating experiments. The modern opportunities of computers and applied programs allow to realize completely the system approach to the description of multifactor dynamic conditions of integrally interdependent links of uniform dynamic system "skip- constant magnet - coil" [2, 3].

During the researches the model of skip motion in mine shaft of was developed. This model is based on effect of magnetic levitation. The essence of the method is concluded in the fact that on a skip or under a skip permanent magnets are located, and on the whole height of mine shaft it is offered to arrange coil windings. In this case the skip with permanent magnets moves in a shaft through the coil. When passing permanent magnets through the coil there is magnetic field which allows the skip to increase speed, thereby moving it up [4, 5, 6].

### 1. The method of calculation

When developing the model of this research the properties of materials are set from library of the ANSYS Maxwell program. For permanent magnet NdFeB element (neodymium – iron - wood) was chosen as material. It is the class of the rare-earth magnets made by pressing or molding of intermetallid Nd<sub>2</sub>Fe<sub>14</sub>B. Advantages of this class of magnets are high magnetic properties (B, H and (B-H) max), and also low cost. Because of weak incorrodibility they are usually covered with copper, nickel or zinc. In our case magnets have to be covered with nickel. For windings of the coil copper was chosen as material. Besides the size of skip and coil [7, 8] were chosen.

5 models with various geometrical parameters of skip and coil were investigated. Initial experiment was made on the model of small size.

## 2. Results and discussion

During the research key parameters which need to be defined were indexes of the magnetic induction vector  $B$ , intensity of magnetic field  $H$  and the Lorentz force  $J$ . The first characteristics specify key parameters of the magnetic field. The Lorentz force is directed on the axis  $z$ , according to the coil location in the mine shaft. The calculation example with determination of parameter  $J$  is shown in figure 1.

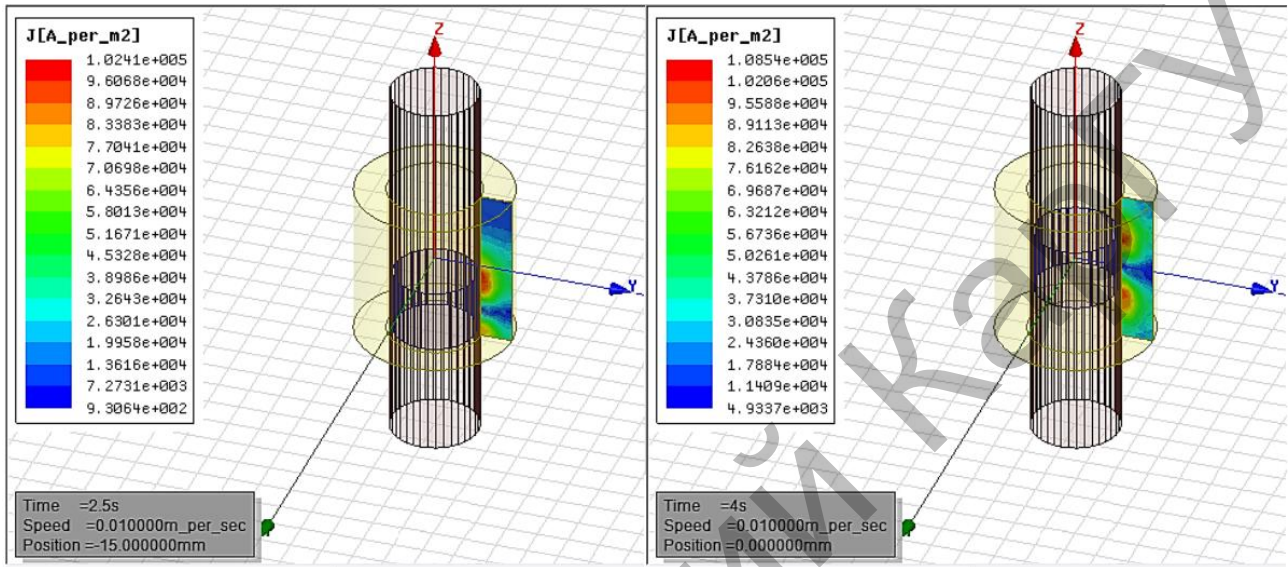

a) at 2,5 second of skip motion; b) at the 4th second of skip motion  
Fig.1. Calculation results of the Lorentz force of initial model

Figures 2 and 3 present stages of the solution of model in which characteristics of induction and magnetic field intensity are defined. To complete the picture interactions the moment of skip finding is presented at 2.5 the color chart on the left the characteristic indicated values from the most minimum at interaction highlighted in the blue color, to the most maximal, highlighted in the red color.

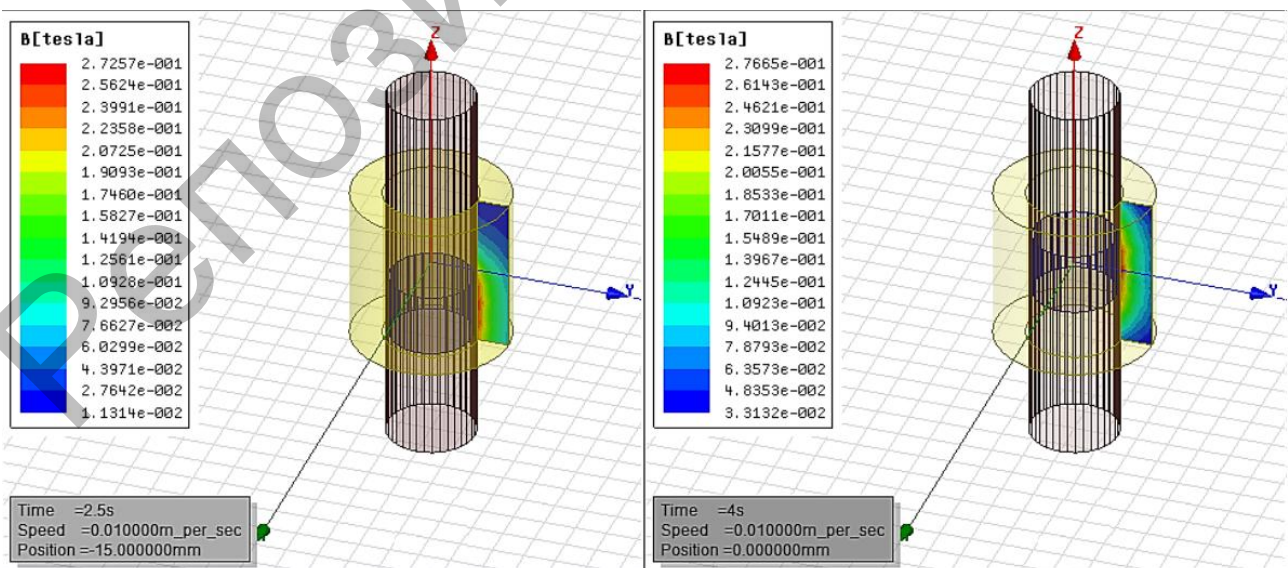

a) at 2.5 second of skip motion; b) at the 4th second of skip motion  
Fig.2. Calculation results of magnetic induction  $B$  of initial models

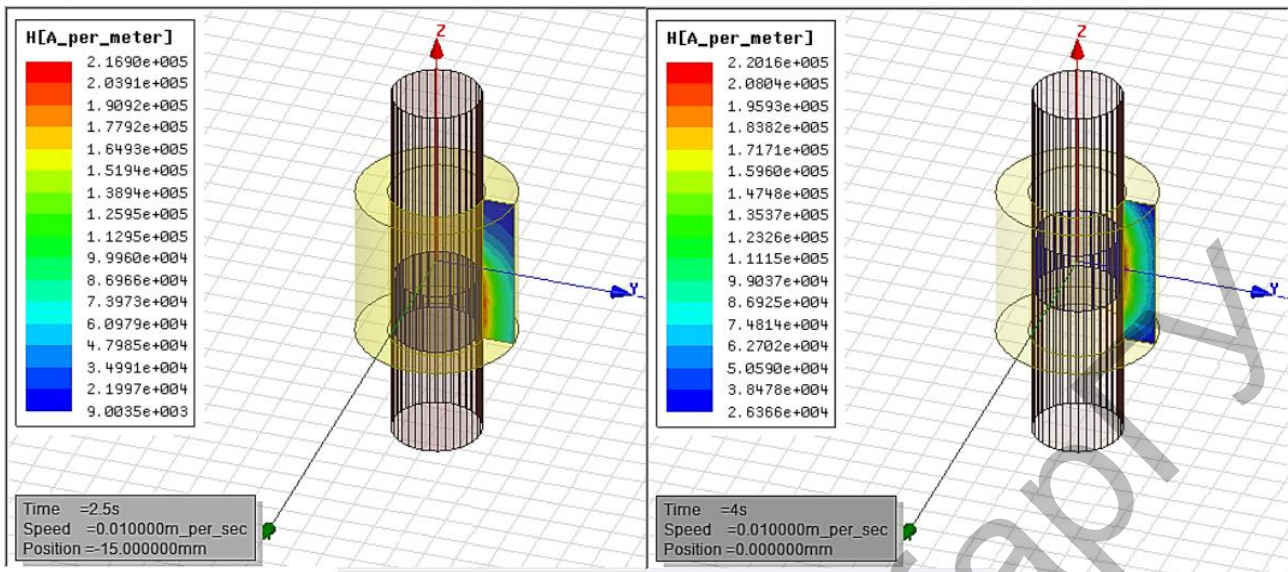

a) at 2.5 second of skip motion; b) at the 4th second of skip motion

Fig.3. Calculation results of magnetic field intensity of initial model

At the initial stage at every second of model interaction the mass of permanent magnets on skip with the coil mine shaft is shown. According to skip location on the model the picture of interaction is changing. By the above described technique 5 models with various geometrical parameters were investigated. By the solution results the families of curves of  $B$ ,  $H$  and  $J$  of each model are constructed. Data for construction are chosen proceeding from the maximal parameters at every second of the conducted research.

In figure 4 the family of dependences of the Lorentz force parameters on time of all five experimental models is presented. Apparently from the schedule, the highest and lowest values of the Lorentz force are observed in model 4.

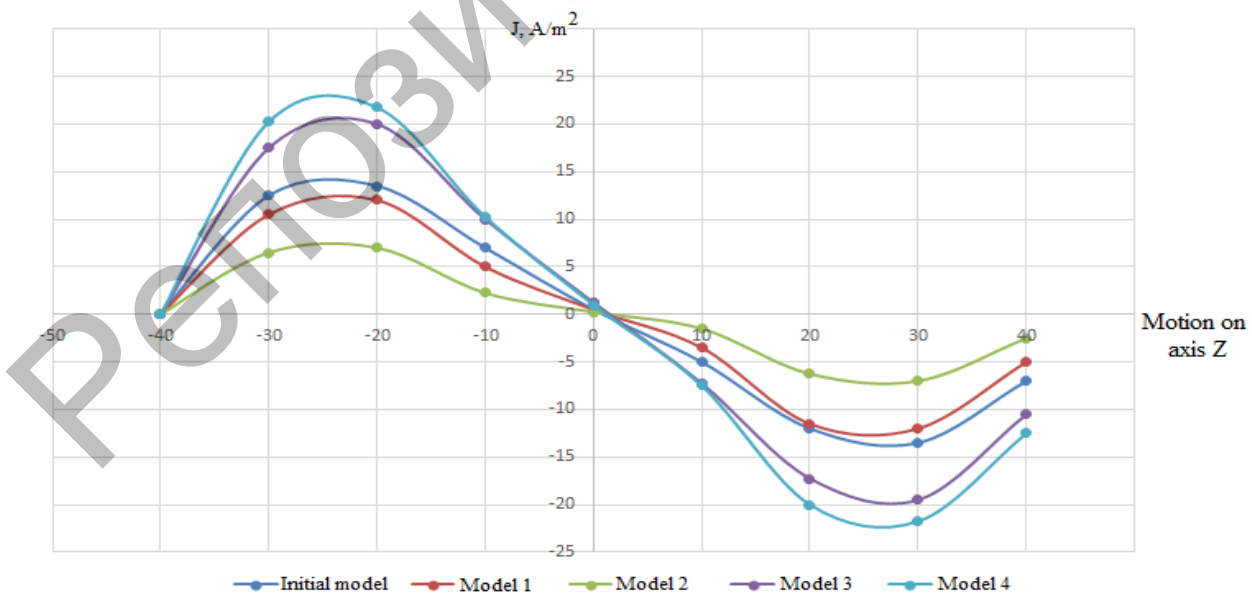

Fig.4. Family of dependences of the Lorentz force on time

While the solution this model was set by the most geometrical parameters. The smallest maximal and minimum values of parameters of the Lorentz force are observed in model 2. This model was set by the smallest geometrical parameters during the solution. Thus, dependence of geometrical parameters is directly proportional to results of the Lorentz force. The more value of geometrical sizes, the more maximal and minimum values of the Lorentz force. The same picture is observed in figure 5 where dependence of parameters of Lorentz force on skip motion on axis Z is presented. The more geometrical parameters of the skip, the more the value of the Lorentz force.

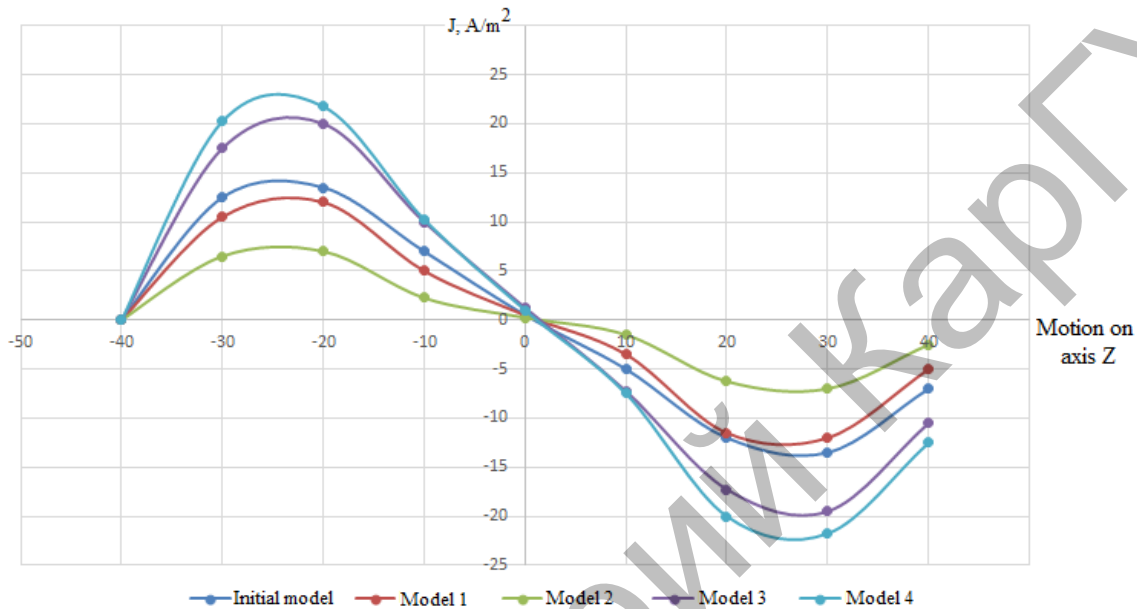

Fig.5. Family of dependences of the Lorentz force on motion on axis Z

In figure 6 the family of dependences of magnetic intensity parameters on time of all five experiment models is presented. Apparently from the schedule, the highest and lowest values of magnetic intensity are observed also in model 4.

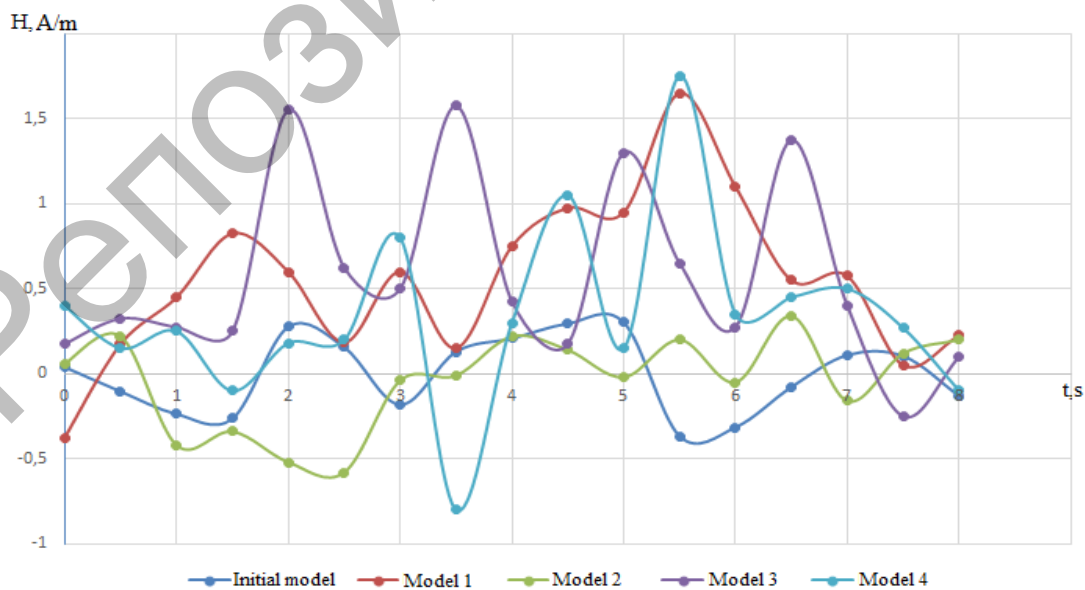

Fig.6. Family of dependences of magnetic intensity on time

The smallest maximal and minimum values of parameters of a magnetic intensity are observed in model 2. While solution this model was set the smallest geometrical parameters. Thus, dependence of geometrical parameters is proportional to the results of magnetic intensity. There are more the value of geometrical sizes, the more maximal and minimum values of parameter H.

In figure 7 more smoothly varying picture is observed. Here, the peaks in model 4 are not observed as leaps of values happened in half shares of seconds, and to motion positions on axis Z in this case there correspond the whole shares of seconds. Therefore, in this case dependence is inversely proportional. The more or less geometrical parameters of a skip, the more smoothly differences of the maximal and minimum values of magnetic intensity presented on graphics. That is parameters will be higher at models 1 and 3 which concerning all models had geometrical values the second and fourth in size respectively.

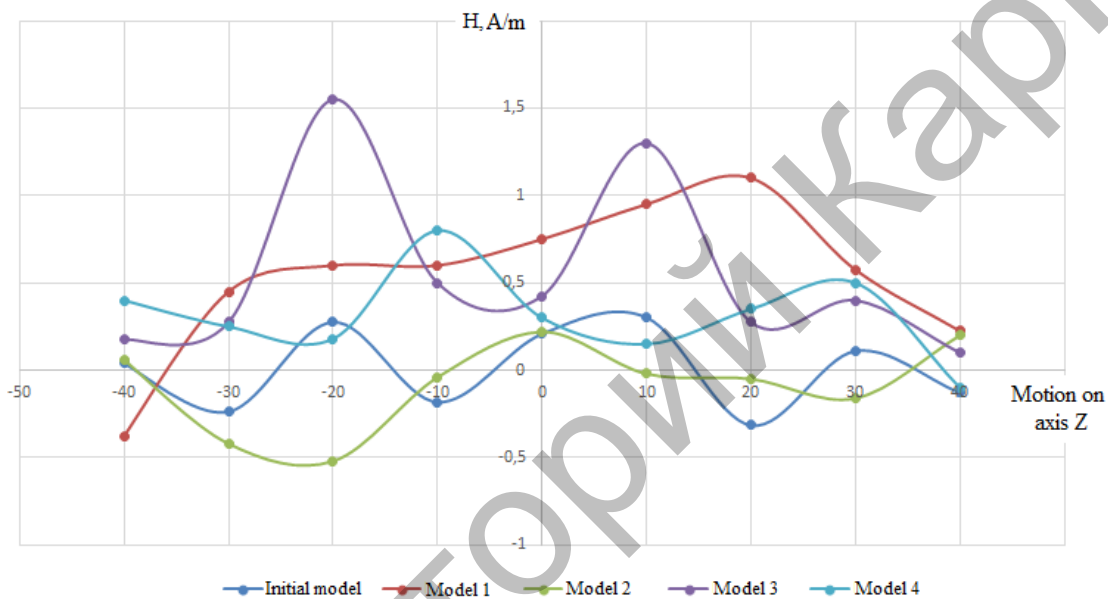

Fig.7. Family of dependences of magnetic intensity on motion on axis Z

In figure 8 the family of dependences of parameters an induction of a magnetic field from time of all five pilot models is presented. Apparently from the schedule, the highest and lowest values of magnetic induction are observed in model 4. The smallest maximal and minimum values of parameters of magnetic field induction are observed in model 2.

Thus, dependence of geometrical parameters is proportional to the results of magnetic induction B. There are more the value of geometrical sizes, the more maximal and minimum values of parameter B. In figure 9 more smoothly varying picture is observed. Here the peaks in model 4 are not observed as leaps of values happened in half shares of seconds, and the whole shares of seconds correspond to motion positions on axis Z in this case. Therefore, in this case the dependence is inversely proportional. The more or less geometrical parameters of a skip, the more smoothly differences of the maximal and minimum values of magnetic field induction are presented in the schedule. That is the parameters will be higher in models 1 and 3 which concerning all models had geometrical values in values were the second and fourth respectively.

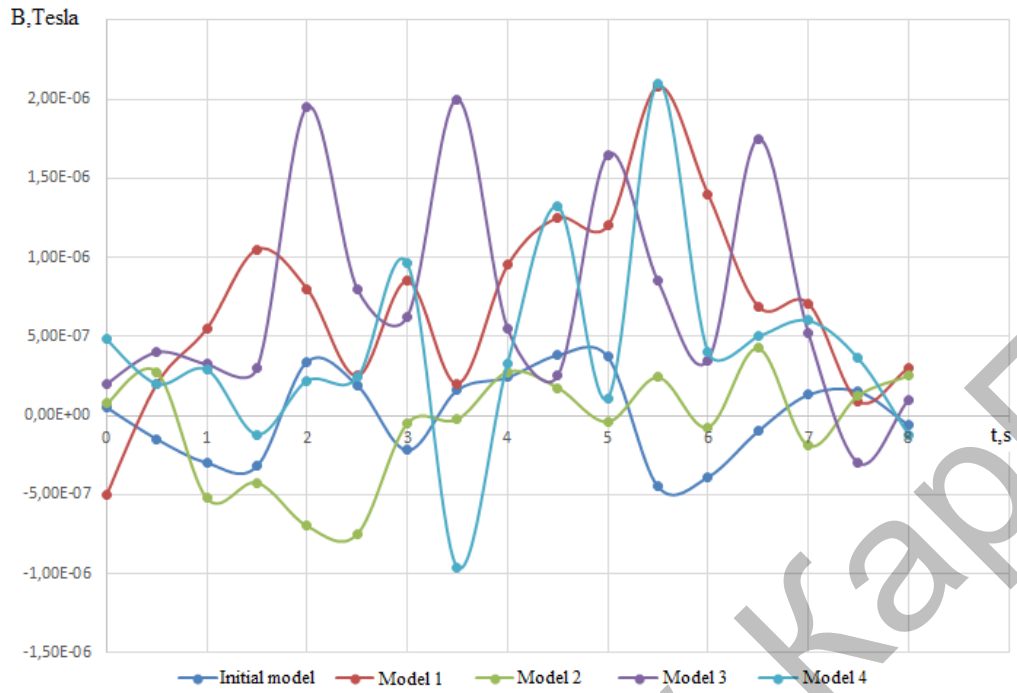

Fig.8. Family of dependences of magnetic field induction on time

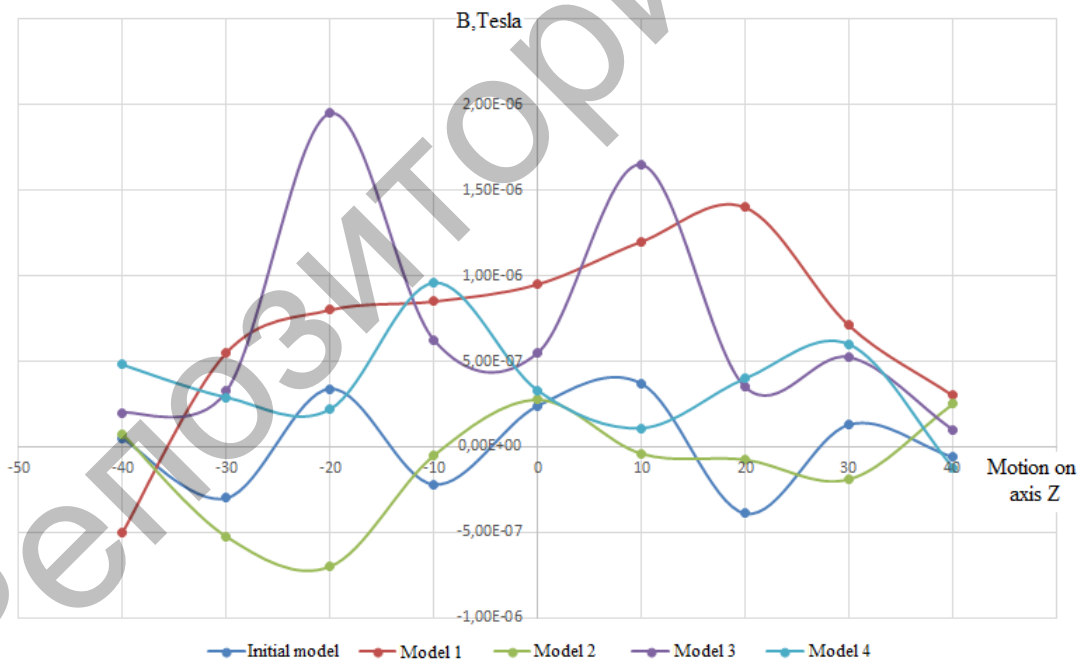

Fig.9. Family of dependences of magnetic field induction on motion on axis Z

## Conclusion

On the basis of the conducted researches the following new scientific results:

- Developed a simulation model in the software environment of ANSYS Maxwell.
- Developed algorithms and software modules in the software package ANSYS Maxwell to determine the electromagnetic force interaction of the array of permanent magnets on the skip and the winding of coil in the shaft.
- When processing the results of the research was obtained non-linear objective functions of the basic magnetic characteristics H, B and J. The equations were written on every second of the experiments. In the research, we changed the radius of a skip, the internal radius of the coil and the external radius of the coil. Objective functions were written regarding this. These functions can be used in the creation of electromagnetic lifting installations.

## Acknowledgments

*The work was supported by the Grant financing of Ministry of Education of the RK, the priority "Power and mechanical engineering", №0686/GF4, "Development of the system of automatic control and complex protection of energy saving electromagnetic lifting installation".*

## REFERENCES

- 1 Zhautikov B. A., Aikeyeva A.A., Zhautikov F.B., Mukhtarova P. A. *Electromagnetic lifting installation (options)*. Innovative Patent of the RK for the invention, № 27177 27177 MJ RK
- 2 Akeyeva A.A. Imitation modeling of dynamics of densing devices in mine pneumolifting installations. *Proceeding of the science-technical conference «Strategiczne pytania światowej nauki – 2008»*. Przemśl: Wydawca Nauka I studia, 2008, Vol. 9, pp. 30 - 34.
- 3 Kazakov Yu.B., Shchelykalov Yu.Ya. Research of magnetic field in the air gap of starter of CT230Б. *Theses of reports of the science-technical conference, Ivanovo, 2008*, pp. 129 - 131.
- 4 Chigarev A.V., Kravchuk A.S., Smalyuk A.F. *ANSYS for engineers: Instr.manual*. Moscow, Mashinostroenie, 2004, 512 p. (in Russia)
- 5 Aikeyeva A.A., Zhautikov B. A., Rogovaya K.S., Zhautikov F.B., Mukhtarova P. A. Application of computer model operation for the choice of parameters of electromagnet. *Automatic equipment and informatics*. Karaganda, KarSTU, 2015, No. 2(37), pp. 71 – 74.
- 6 Aikeyeva A.A., Zhautikov B. A., Rogovaya X.S., Zhautikov F.B, Mukhtarova P.A. 3-D modeling of elements of skip-electromagnet system. *Eurasian Physical Technical Journal*. Karaganda, 2015, No. 2(24), pp. 28 - 32.
- 7 Aikeyeva A.A., Zhautikov B. A., Zhanasbayeva A.S., Mukhtarova P. A. Research of loads on the skip of mine and career electromagnetic lifting installation. *Bulletin of the Karaganda State University*, Karaganda, 2015, No. 3(79), pp. 90 - 95.
- 8 Aikeyeva A.A., Zhautikov B. A., Zhautikov F.B., Mukhtarova P. A. The research loads on the skip of mine and quarry electromagnetic lifting installation. *Eurasian Physical Technical Journal*. Karaganda, 2015, No.1 (23), pp. 59 - 64.