

UDC 537.533.34

CALCULATION AND MODELING OF THE MOTION OF CHARGED PARTICLES IN THE QUADRUPOLE-CYLINDRICAL FIELD

Kambarova ZH.T.¹, Saulebekov A.O.²

¹ Ye.A. Buketov Karaganda State University, Universitetskaya Str.28, Karaganda, 100026, Kazakhstan

²Lomonosov Moscow State University, Kazakhstan branch, Kajimukana str. 11, Astana, 010010, Kazakhstan
kambarova@bk.ru

The electron-optical scheme of the electrostatic energy analyzer on the basis of the quadrupole-cylindrical field is proposed. The outer electrode of the proposed energy analyzer has a cone profile, the generatrix of which is a small angle of inclination with respect to the symmetry axis of the mirror, equal to 1.75 deg. Calculation of particle-optical parameters of the energy analyzer is carried out. Advantages of this field are shown. Initial parameters of the motion of charged particles, optimal from the point of view of the luminosity and resolution ability are given.

Keywords: energy analyzer, electrostatic field, quadrupole-cylindrical mirror, corpuscular-optical parameters, angular focusing.

Introduction

Many types of diagnostics of structures and composition of nanometer objects and nanosystems are based on an accurate analysis of energy spectrum of secondary electrons. A promising base for the required diagnostics is electron spectroscopy methods, which are characterized by a nanometer resolution in the solid depth. Energy analyzers with different geometries of fields are most often used for purposes of energy analysis.

Calculation of the structure of electrostatic quadrupole-cylindrical fields was calculated in [1]. Equipotential portraits of quadrupole-cylindrical fields with various contributions of the cylindrical field and the quadrupole are obtained. Results of the analysis of obtained equipotential portraits of quadrupole-cylindrical fields are presented.

Work [2] is devoted to the development of the mirror type energy analyzer based on the electrostatic quadrupole-cylindrical field. Focusing properties of the electron-optical scheme of the energy analyzer with “shaping parameter” $A = - 0.05$ are determined. The regime of second-order “ring-ring” type angular focusing is found. Corpuscular-optical parameters of the electrostatic quadrupole-cylindrical mirror are investigated in present work. The quadrupole-cylindrical field is constructed on the basis of the superposition of the cylindrical field $\mu \ln r$ and the axially-symmetric cylindrical quadrupole:

$$U_q(r, z) = U_0 (\mu + z) \ln r \tag{1}$$

where μ is the coefficient that determines the weight contribution of the cylindrical field.

The quadrupole-cylindrical field (1) at value $\mu = 1$ coincides with the well-known Wannberg field [3]. The potential of the Wannberg field in the coordinate system r, z is described by the following expression

$$U = \frac{V}{\ln \frac{r_1}{r_0}} (1 + Az) \ln \frac{r}{r_0} \tag{2}$$

where A is a small dimensionless parameter.

Wannberg numerically found that the analyzer on the basis of the proposed modified potential field (2) provides simultaneous focusing in the wide energy range and the focal surface can be approximated to the surface of the inner cylindrical electrode (at $r = r_o$) for energies within 7-16% of the central energy.

1. Calculation of corpuscular-optical parameters of the quadrupole-cylindrical mirror

Fig.1 shows the scheme of the energy analyzer with “ring-ring” type focus. The field is formed in the space between two axially-symmetric coaxial electrodes. The inner cylindrical electrode (radius r_o) is grounded. The outer electrode under the potential U creates nonuniformity of field

and has the curvilinear profile $r = r_o \exp\left[\frac{\ln(r_1/r_o)}{(1 + Az)}\right]$.

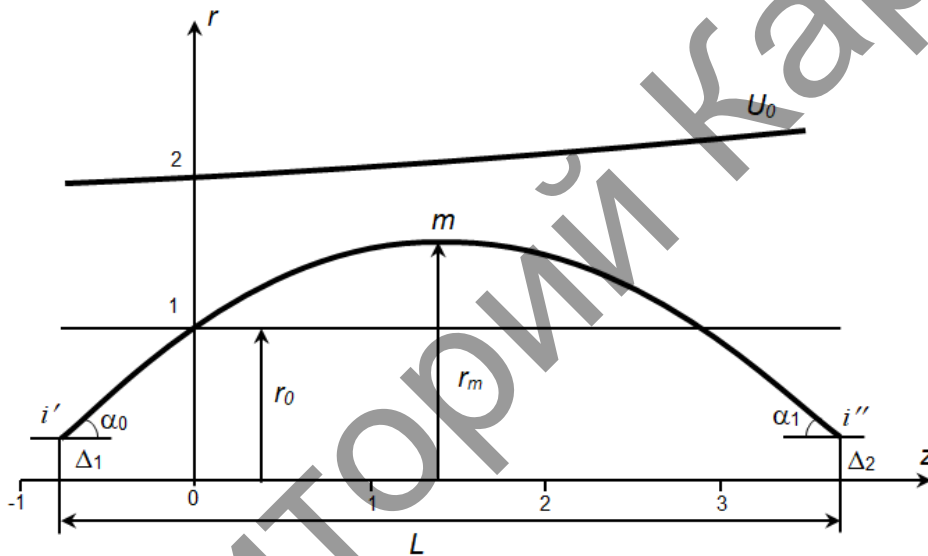

Fig.1. The scheme of the quadrupole-cylindrical energy analyzer

Schemes of quadrupole-cylindrical energy analyzers with various contributions of the dimensionless parameter $A = + 0.01, A = 0, A = - 0.01$ are studied. The “ring-ring” type focusing is considered for all schemes (the ring source of charged particles and the ring detector are located near the inner cylindrical electrode).

For analyze of parameters of the electrostatic quadrupole-cylindrical energy analyzer, first, second and third order aberration coefficients of spatial focusing were determined by the approximate-analytical method of calculation of the charged particles trajectory:

$$A_I = \frac{dl}{d\alpha} = \Delta_1 [1 + \text{ctg}^2 \alpha_0] + \frac{d\xi_i}{d\alpha} + \Delta_2 \frac{d}{d\alpha} (\text{ctg} \alpha_1), \tag{3}$$

$$A_{II} = \frac{d^2 l}{d\alpha^2} = 2\Delta \text{ctg} \alpha_0 [1 + \text{ctg}^2 \alpha_0] + \frac{d^2 \xi_i}{d\alpha^2} + \Delta \frac{d^2}{d\alpha^2} (\text{ctg} \alpha_1), \tag{4}$$

$$A_{III} = \frac{d^3 l}{d\alpha^3} = -2\Delta [1 + 4\text{ctg}^2 \alpha_0 + 3\text{ctg}^4 \alpha_0] + \frac{d^3 \xi_i}{d\alpha^3} + \Delta \frac{d^3}{d\alpha^3} (\text{ctg} \alpha_1), \tag{5}$$

where ξ is projection of the trajectory of charged particles on the symmetry axis z of the mirror in the section from i' to i'' ;

Δ_1, Δ_2 are values of the distance from the source and its image to the surface of the inner cylindrical electrode (Fig. 1), $\Delta = \frac{\Delta_1 + \Delta_2}{2}$ is the value of the average total distance;

$l = \frac{L}{r_0}$ is the total projection of the particle trajectory on the symmetry axis z of the mirror from the source to its image.

Fig. 2 allows to compare the focusing quality of schemes with different values of the “shaping parameter” A . The dependence of the cubic angular aberration coefficient A_{III} on the entrance angle α_0 of charged particles is showed here. As can be seen from Fig. 2, with increasing of the entrance angle α_0 , an increase of the cubic angular aberration coefficient is observed, which leads to a decrease of the resolution ability of the energy analyzer.

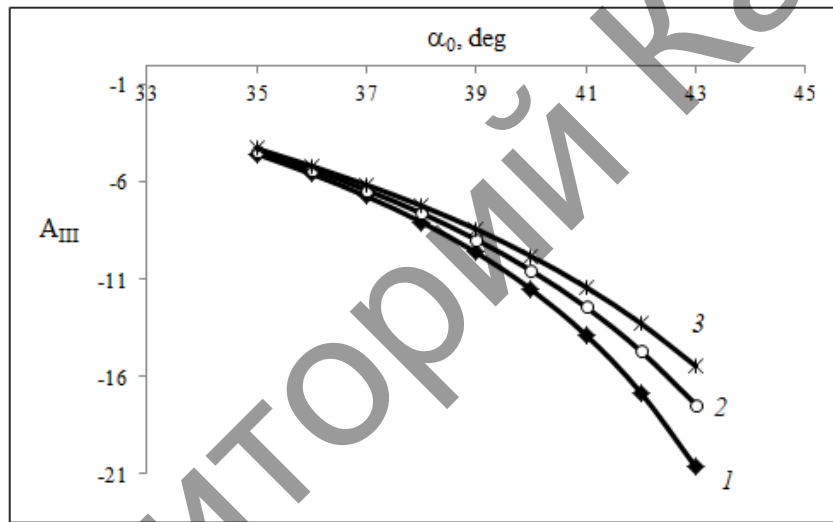

1 - scheme with $A = +0.01$, 2 - scheme with $A = 0$, 3 - scheme with $A = -0.01$.

Fig.2. The dependence of cubic angular aberration coefficient A_{III} on entrance angle α_0

Comparison of parameters of electron-optical schemes with different values of “shaping parameter” A shows that cubic angular aberrations coefficients A_{III} of schemes with $A < 0$ are smaller than for schemes with $A > 0$ and smaller than for the cylindrical mirror analyzer corresponding to schemes with $A = 0$. This means that mirror analyzers based on quadrupole-cylindrical fields with improved particle-optical parameters should be chosen among schemes with $A < 0$.

2. Results and discussion

Results of the numerical modeling of the scheme of the quadrupole-cylindrical energy analyzer with $A = -0.01$ are given below. Numerical modeling was carried out by using the “Focus” program [4] for modeling systems of electronic optics.

The profile of the outer deflecting electrode is determined from the calculation of equipotential lines of the quadrupole-cylindrical field. Fig.3 shows equipotential lines of the electrostatic quadrupole-cylindrical field with $A = -0.01$.

As can be seen from Fig. 3, for a small value of $A = -0.01$, the profile of the outer deflecting electrode is well approximated by a cone whose generatrix has a small inclination angle with respect to the symmetry axis z of the mirror, equal to ~ 1.75 deg.

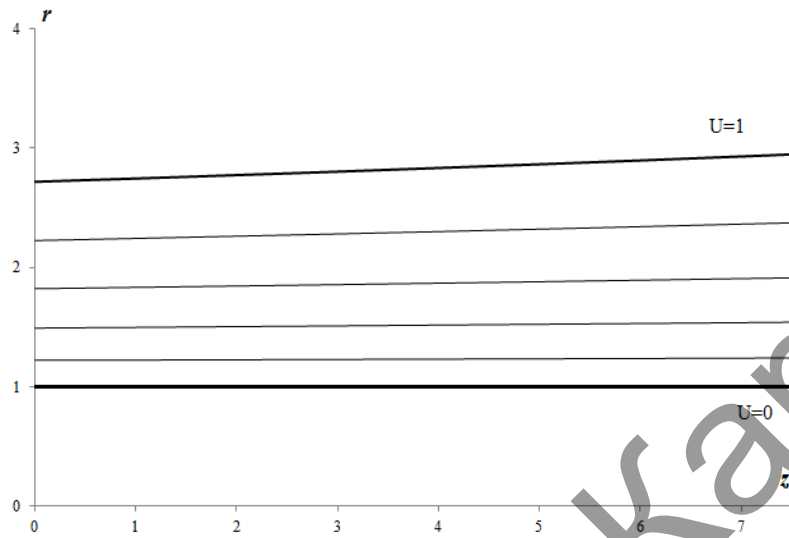

Fig.3. Equipotential lines of the quadrupole-cylindrical field with $A = -0.01$

Fig. 4 shows the dependence of the arrival point of the particle (the point z') from the entrance angle α_0 . It follows from Fig.4 that the optimum range of entrance angles of particles is the angle interval from $35^\circ - 45^\circ$, which provides a maximum luminosity $\Omega = 8.2\%$ and the best focusing of charged particle beam.

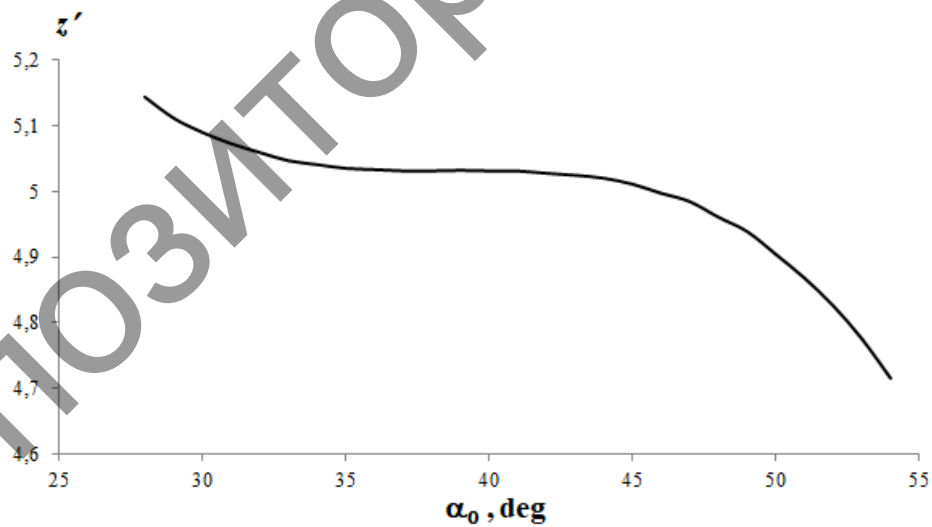
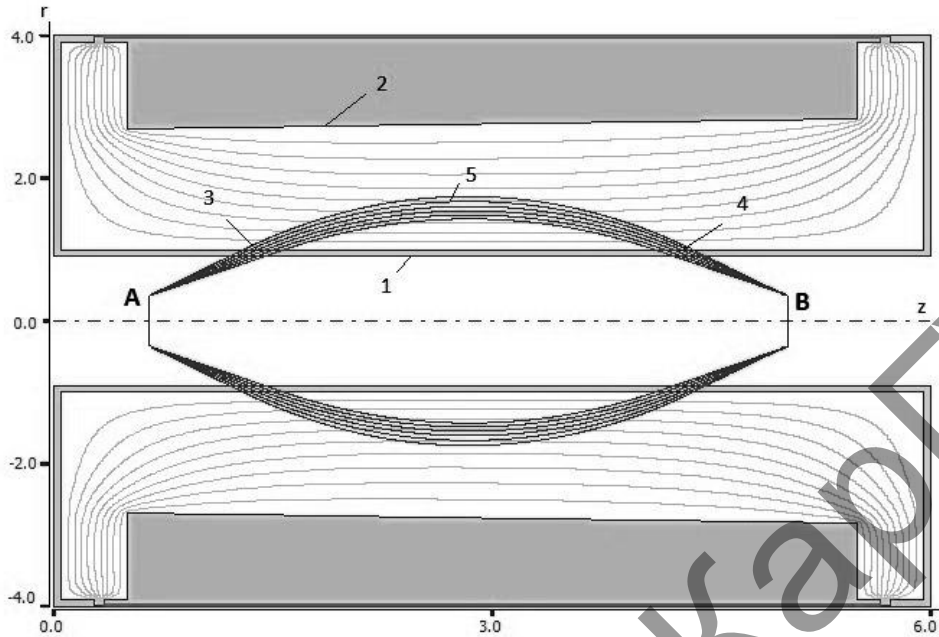

Fig. 4. The dependence of the arrival point of the particle on the entrance angle α_0

Fig.5 shows trajectories of charged particles in the energy analyzer scheme with $A = -0.01$, calculated by using the “Focus” program. According to the scheme, charged particles fly from the thin ring electron-optical source A in the range of polar angles from 35° to 45° , then get through the entrance slit in the field, and under the action of the potential of the outer electrode are deflected back, and are focused into the ring image B.



1 – the inner grounded cylindrical electrode, 2 – the outer deflecting electrode, 3 and 4 - entrance and exit slits, A - thin ring source, B - ring image, 5- charged particles beam

Fig.5. Trajectories of charged particles beam in the quadrupole-cylindrical energy analyzer with $A = -0.01$

The scheme provides the second-order “ring-ring” type angular focusing regime. The relative energy of the particles is $E/U = 1$. The position of the ring source is $x = 0.65$; $y = 0.35$. Values of the distance of the source and its image from the surface of the inner cylindrical electrode, which are considered positive inward from the radius r_0 , are equal to $\Delta_1 = \Delta_2 = 0.35$. All dimensions are expressed in conventional units. The table presents results of calculation of corpuscular – optical parameters of the energy analyzer on the basis of the quadrupole-cylindrical field at $A = -0.01$.

Table 1. Corpuscular – optical parameters of the energy analyzer on the basis of the quadrupole-cylindrical field at $A = -0.01$

Focusing type	«ring-ring»
Focusing order	2
Center focusing angle	38.3^0
X coordinate of focusing	5.03
Y coordinate of focusing	0.35
The total length of the electron-optical scheme, $l = L/r_0$	6
Reflection parameter, P	1

For calculate the instrumental function of the quadrupole-cylindrical energy analyzer, particles from the ring source start in the range of the initial angles of $35^\circ - 45^\circ$ and in the range of initial energies 0.993-1.007. Fig. 6 shows the instrumental function of the proposed energy analyzer at $A = -0.01$ for the “ring-ring” type angular focusing regime. The relative energy resolution at half-height of the instrument function of the energy analyzer with a radius of the exit diaphragm $0.02 r_0$ is 0.58%.

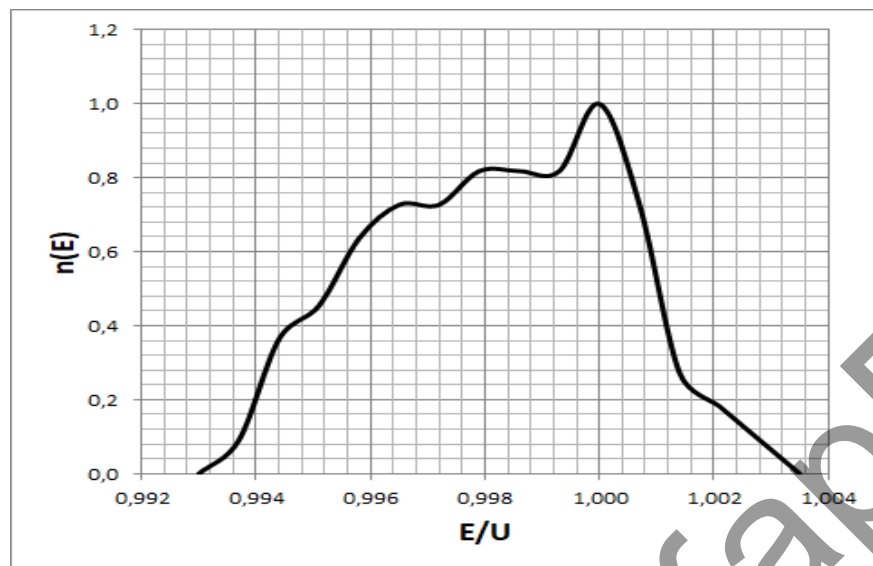

Fig. 6. The instrumental function of the quadrupole-cylindrical energy analyzer with $A=0.01$

Conclusion

Investigation of corpuscular-optical parameters of the energy analyzer on the basis the quadrupole-cylindrical field is carried out. It is shown that the best quality of focusing has the scheme with $A = -0.01$, whose the outer electrode has an increasing exponential profile at a small angle of inclination relative to the symmetry axis of the mirror, equal to 1.75° . For ensure maximum luminosity, the range of entrance angles of particle of start should be from 35° to 45° (in this case luminosity is 8.2%).

REFERENCES

- 1 Kambarova Zh.T., Saulebekov A.O. Calculation of the structure of electrostatic quadrupole-cylindrical fields. *Bulletin of the Karaganda University. «Physics» series.* 2018, No. 1 (89), pp. 66 – 71.
- 2 Kambarova Zh.T., Saulebekov A.O. Development of mirror energy analyzer based on electrostatic quadrupole-cylindrical field. *Eurasian Physical Technical Journal.* 2017, Vol.14, No 2 (28), pp. 42 – 47.
- 3 Wannberg B. An electrostatic mirror spectrometer with coaxial electrodes for multi-detector operation. *Nuclear Instruments and Methods.*1973, Vol.107, pp. 549 – 556.
- 4 Trubitsyn A., Grachev E., Gurov V., Bochkov I., Bochkov V. *Proceedings of SPIE.* 2017, Vol.10250, pp. 0V-1 – 0V-7.