

UDC 53.06; 53.043

**DYNAMICS OF AN ELECTRICAL DISCHARGE IN THE GAS-LIQUID FLOW IN THE PIPERS WITH VARIABLE CROSS SECTION**

K. Kusaiynov, S.E. Sakipova, D.A. Ospanova, K.E. Ahmerova

State University named after E.A. Buketov, Universitetskaya Str.28, Karaganda, 100026, Kazakhstan

*The paper is devoted to experimental study of hydrodynamic characteristics of underwater electrical explosion in fluid flowing through pipes with variable cross sections. A brief description of the experimental plant, producing an underwater electrical discharge in the liquid flowing within the diffuser or confuser, is given. The experimental results for gas-fluid flows, with varying degrees of gas content are given. It is shown that increase of gas content results in decrease in the pressure pulse amplitude, as compared to its value in pure water. Decrease in the amplitude of the pulse pressure in the diffuser is slower than in the confuser.*

**Keywords:** hydrodynamic characteristics, electrical explosion, electrical discharge, gas content, pulse pressure.

**Introduction**

The electrohydraulic effect is considered to be one of the industrial practices of direct conversion of electrical energy into mechanical one without any intermediate steps. The main point of electrohydraulic effect is in occurrence of hydraulic shock waves at high-voltage pulse electric discharge in liquid, as the result of its incompressibility [1,2].

The relevance of underwater electrical discharge is due to the importance of its use in a wide variety of technological processes, where powerful energy of generated shock waves is widely used for pressing granular media or crushing hard rocks. The pulse pressure at the front of the shock wave, generated by electrical discharge in the liquid, can be used to destroy solid deposits on inner surfaces of pipes of heat exchangers, pipelines, oil pipelines, etc.

The amplitude of the pulse pressure, which acts in a very short period of time during the  $\sim 10^4 \div 10^5$  s reaches the level of  $\sim 10^8 \div 10^9$  n/m<sup>2</sup>. The value of the amplitude of pulse pressure depends on the condition of work medium and of geometry of the work area, where the shockwave propagation takes place [1-3].

In modern power engineering, and in many industrial processes, process water with added various chemical reagents is commonly used as a work medium. Therefore, the work medium is most often a two-phase and sometimes multi-phase gas-liquid medium. This greatly affects the dynamics of the electro-hydraulic effect. Moreover, the composition of the gas component in the liquid flow is of great importance itself. For example, the same percentage of air or carbon dioxide in the liquid, where the electric discharge goes on, can lead to both increase and decrease in the amplitude of pressure. As to the geometry of the work area, it is well known that cylindrical pipes are used for the transportation of liquids and various heat carriers. In the joints to the heat source or at transmission to customers there are interjacent narrowing or widening pipe sections - diffusers and confusers. It turns out that widening or narrowing of the pipe also affects the propagation of shock wave caused by electro-hydraulic effect. The paper is devoted to the study of impact of these factors on the dynamics of underwater electrical discharge.

**Experimental plant and measurement technique**

In the laboratory of Hydrodynamics and heat transfer a laboratory apparatus for an experimental study was assembled, its scheme is shown in Figure 1. The apparatus consists of an energy storage device, charger, control panel and technology block, which has a vessel of water with built-in system of electrodes, forming a channel of a pulse electric discharge. Battery

capacitors are connected to the system of electrodes in the technology block through the arrester. The charger makes it possible to charge the capacitor to a voltage necessary for discharge [4].

To obtain a two-phase gas-liquid flow in which the electrical discharge and the propagation of shock waves take place, a specialized technology block has been made, its diagram is shown in Figure 2. This block makes it possible to investigate the effect of the degree of gas content on the pulse pressure of high voltage electrical discharge in a heterogeneous liquid. In addition to a pump, a sensor, gauges, consumable washers, a gas cylinder, the system of electrodes, etc., there are removable parts of the pipe with variable cross-section, i.e. a confuser and diffuser.

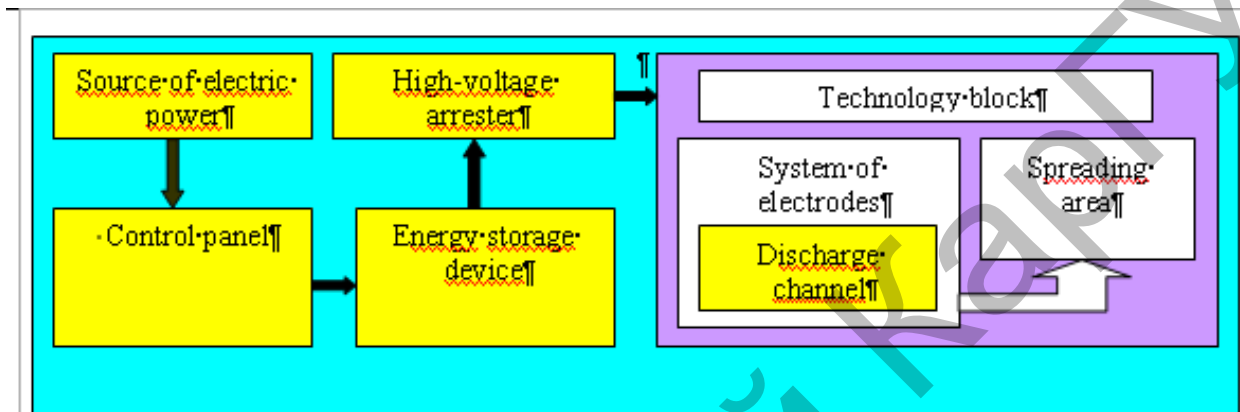

Fig.1. A scheme of the experimental plant.

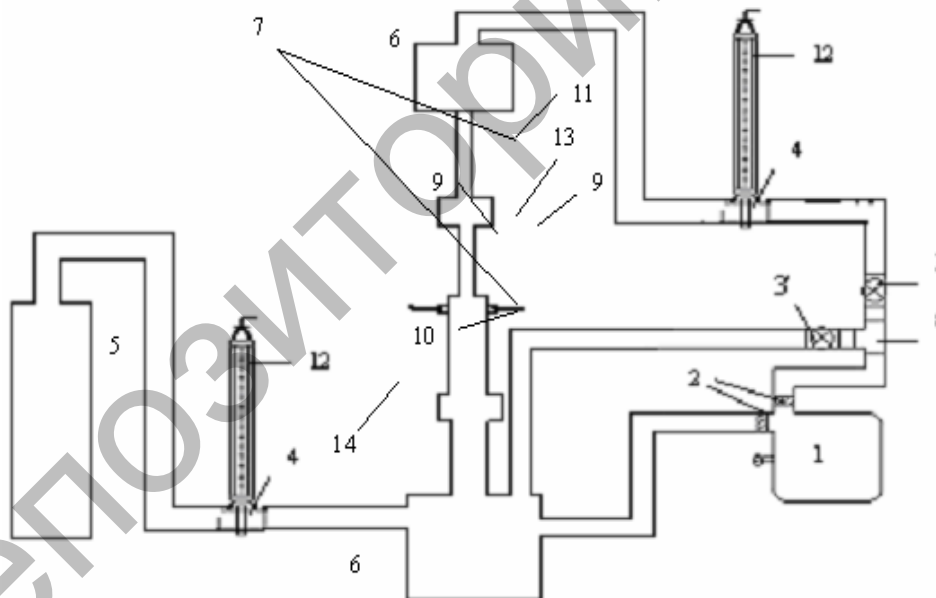

Fig. 2. Diagram of a technologyblock producing a heterogeneous liquid flow. 1- a pump, 2- adaptors, 3- cocks, 4- consumable washers, 5- gas cylinder, 6- water tanks, 7- sensors, 8-T- tube, 9- electrodes, 10- big-diameter pipe, 12-dif. gauges, 13- conical section, 14- retaining valve.

To measure the rate used in the experiments a piezometric pressure sensor (7) was used, the scheme of which is shown in Figure 3. The piezometric sensor consists of the case 1, the piezoelectric element 2, the coaxial cable 3; the piezoelectric element is located in the central core of the cable 4. A flat end of the piezoelectric element adjoins the membrane 5 and the other end, made in the form of a cone, rests on the washer 6 with the inner conical surface, between them there

is the cable shield 7. The washer is set on a bulge of an isolation barrier 8, which is installed through the ring 9 on the inner side of the frame. The shank 10 is made with the internal kerbing ribs, forming the upper insulating layer of cable.

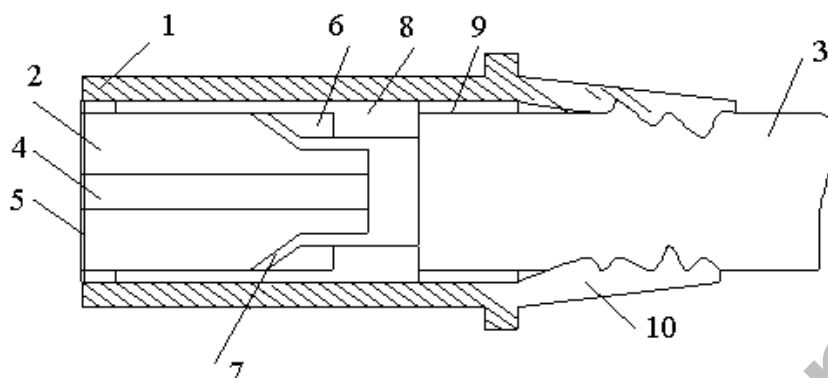

Fig. 3. Scheme of the piezometric sensor for measuring the pulse pressure

The principle of operation of the sensor is as follows: the pulse pressure acting on the membrane is transmitted to the piezoelectric element, which produces an electric signal transmitted through the waveguides to the recording device – a storage oscilloscope. The piezometric sensor of this design makes it possible to measure the pressure pulses with an amplitude of up to the amount of 50-60 bar and a very small length of the measured signal  $\sim 0,001 \div 0,005$ s.

The calibration of the sensor was carried out at the set up state of the work area of the pilot stand by the dynamic method. At the calibration the cover of the work area was replaced by a device consisting of a cylinder and piston. For given hydraulic power of a stroke of the piston electrical signals from the piezometric sensor were recorded using the storage oscilloscope. The calibration chart of pulse pressure sensor was obtained as a result of tests conducted at the Institute of Thermophysics SB RAS, Russia. The results of systematic tests showed that the relative scatter of experimental points is about 5-7%.

## Results

In the experiments, values of the energy storage capacity and inductance of the discharge circuit were maintained constant, the electrode spacing varied from 0.5 to 5 mm, and accordingly, the discharge voltage was changed. On the pulse sweeps, the maximum peak corresponds to the pressure which is recorded by the piezometric sensor immediately after the passing of an electric discharge in a liquid, the next lower peaks correspond to the pressure caused by the reflected shock wave. Further recorded pressure pulses correspond to damped oscillations in a medium in which an electrical explosion took place.

Figure 4 shows the dependence of the amplitude of pulse pressure resulting from an electric discharge in a gas-liquid medium with different concentrations of the gas component and measured in the diffuser and confuser. The axis of ordinate shows the values of the amplitude of the pulse pressure  $P$ .

The values of  $\beta$  - volumetric concentration, which is determined by the ratio of the volume of the gas phase  $V_g$  to the total volume:  $\beta = \frac{V_g}{(V_l + V_g)}$ , are plotted at the axis of abscise.

At the experiments the corresponding values of the distance between the electrodes  $l$  are 1mm and 4mm. Figure 4a shows that in the diffuser the amplitude of the pulse pressure decreases almost uniformly from 8.9 bar to 7.6 bar in the whole range of gas concentration changes.

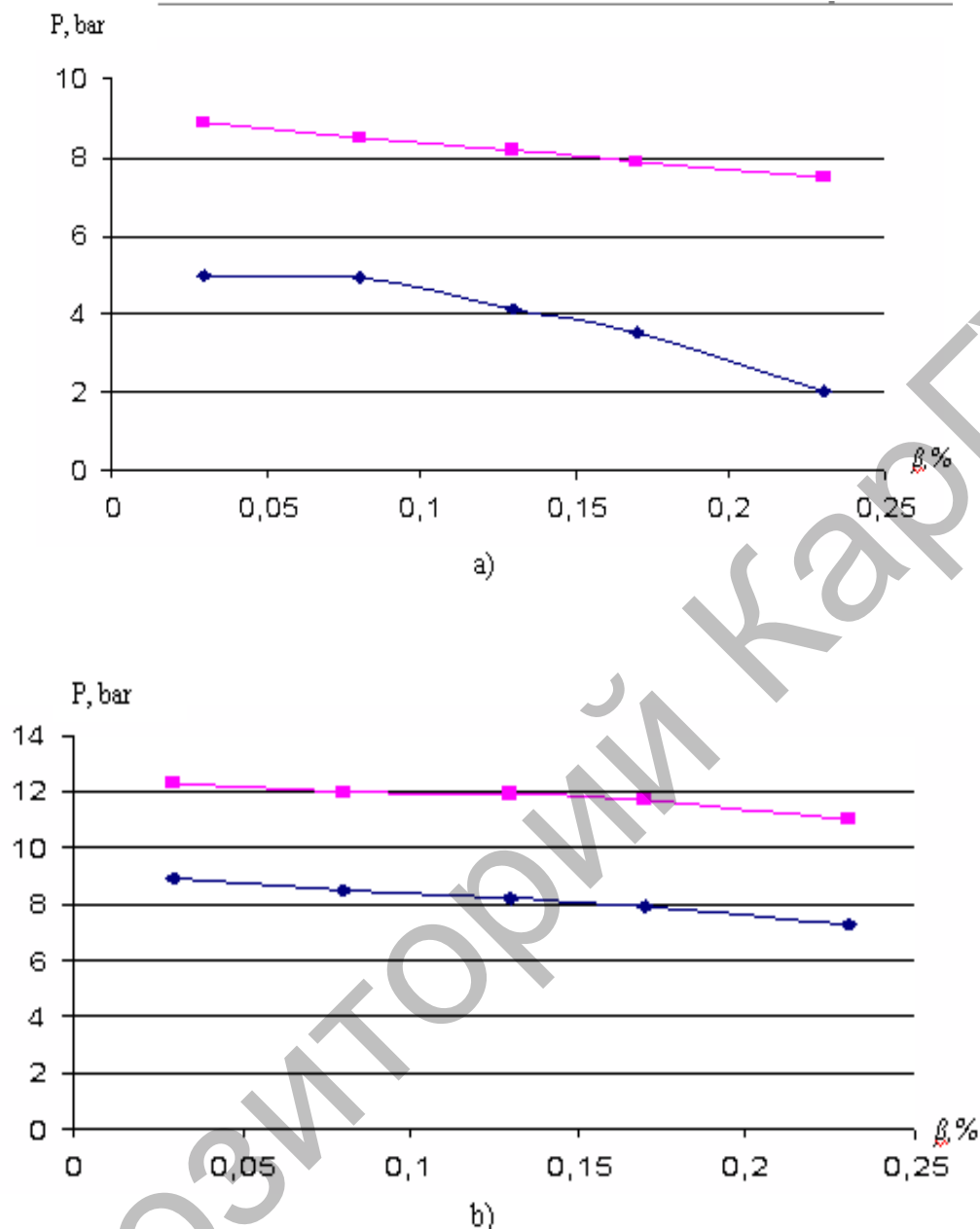

Fig. 4. The dependence of the amplitude of pulse pressure on the degree of gas content in the two-phase flow when flowing in the diffuser (■) and confuser (◆),  $C = 0.1$  mF, the discharge voltage  $U =$ : a) 3 kV, b) 12kV.

In the confuser the amplitude of pulse pressure at the gas phase concentrations (0.05-0.15)% does not change, and then abruptly drops from 5 bars to 2 bars. Further increase in the degree of gas content leads to a decrease in the amplitude of the pressure due to the deformation effect of the gas phase [5]. Figure 4b shows a similar picture - with the increasing in the degree of gas content from (0.05 to 0.25)% in the diffuser, the amplitude of the pulse pressure decreases from 12.2 bar to 11 bar, and in the confuser - from 9 bar to 7.8 bar.

Figure 5 shows the dependency graph of an amplitude of pulse pressure on the degree of gas content at different interelectrode distances in a gas-liquid flow when flowing in the diffuser and confuser. Addition of a gas phase to the concentration of 0.25% hardly effects the value of the pressure amplitude, but further increase in the gas phase content leads to a reduction, there is a damping effect of the gas phase. Decrease in the pressure amplitude with increase in gas

concentration in the stream flowing through pipes with variable cross section, is almost identical to the change of the interelectrode distance.

It was previously found that in the diffuser at low speeds due to the decrease in pressure along the diffuser the sizes of gas bubbles change [3-6].

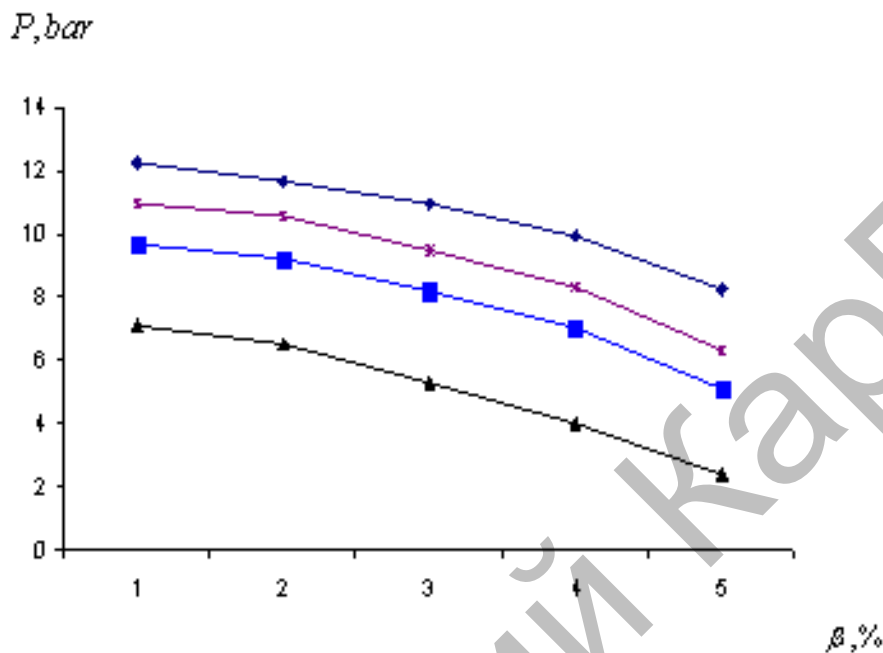

Fig. 5. The pressure amplitude dependence on the content of the gas medium in the flow (water + air bubbles) with an interelectrode distance of  $l =$ :  $\blacklozenge$  - 4 mm;  $*$  - 3 mm;  $\blacksquare$  - 2mm;  $\blacktriangle$  - 1mm

Thus, with increase in the degree of gas content, the amplitude of the pulse pressure decreases as compared to its value in pure water, and the decrease in the amplitude of pulse pressure in the diffuser being slower than in the confuser. The gas phase along the diffuser is spread out evenly, but its type depends on the  $s$  of the bubbles that form clusters. The effect of non-uniform changes in the amplitude of pulse pressure in the diffuser is due to the fact that clustering leads to the formation of gas bubble structures that affect the hydrodynamics of an electric discharge in a gas-liquid flow.

#### References:

1. Kedrinskij V.K. Shock waves in liquids with bubbles of gas. //Physics of combustion and explosion-1980, V. 16, N 5. - P. 14-15.
2. Yutkin A.A. Electrohydraulic effect and its application in the industry. - L.: Mashinostroenie, 1986 -253 p.
3. Kusaiynov K. Hydrodynamics, heat transfer and electro-hydraulic phenomena at two-phase flow in pipes. - Karaganda: Karaganda State University, 1998. - 114 p.
4. Kusaiynov k., Sakipova S.E., Ospanova D.A., Kurmasheva K.E. The study of the dynamics of pulse pressure at the motion of an inhomogeneous fluid through the channels of variable section. Recent achievements in physics and fundamental physical education: Collection of scientific papers of the 6<sup>th</sup> international scientific conf. - Almaty: Kazakh university. -2009. - P. 25-27.
5. Kusaiynov K., Sakipova S.E., Satybalidin N.M., Ospanova D.A. Modeling of the Dynamics of Pulsed electric discharge in the heterogeneous environment. Methods of Aerophysical Research: The papers of 13th International conference ICMAR-2007. Proceeding. Part V. - Novosibirsk: Publishing House «Parallel».- 2007.-P.98-102.
6. Kusaiynov K., Sakipova S.E., Ospanova D.A., Kurmasheva K.E. Research of dynamics of pulse pressure in heterogeneous liquid. Eurasian Physical Technical Journal.-Karaganda: KarSU, 2009, Vol.6, №1(11). - P.32-37.