

A.Zh. Tleubergenova<sup>1,2\*</sup>, A.N. Dyusembayeva<sup>1</sup>, N.K. Tanasheva<sup>1,2</sup>,  
Sh.S. Kyzdarbekova<sup>1</sup>, A.R. Mukhamedrakhim<sup>1</sup>

<sup>1</sup>Karaganda University of the name of academician E.A. Buketov, Kazakhstan;

<sup>2</sup>Scientific Center "Alternative Energy", Karaganda, Kazakhstan  
(\*e-mail: shykent.a7@mail.ru)

## Analysis of aerodynamic characteristics of a two-bladed wind power plant containing combined power elements

In this article, the aerodynamic characteristics of a wind turbine of various parameters are studied. For this purpose, an experimental two-cylinder model with fixed blades was made. A schematic diagram of a wind turbine with fixed blades and rotating cylinders is obtained. The airflow velocity varied from 3 to 12 m/s. The dependences of the aerodynamic forces of a wind power plant on the flow velocity were investigated. The analysis of the results of the experiment on changing the angle  $\alpha$  of the fixed blade relative to the cylinder from the airflow velocity of the wind turbine is carried out. When the position of the blade changes, the drag changes relative to the airflow. A graph is constructed based on the dependence of drag and lift forces on the flow velocity. It is established that at the maximum angle relative to the cylinder  $\alpha = 30^\circ$  that the value of the lifting force and the drag force of the fixed blade is higher. From the dependence of the coefficient of lift and drag force on the Reynolds number, it was found that at an angle of  $30^\circ$  degrees, there is a minimum lifting force of 0.04 and a maximum drag force of 1.479 at  $Re=1 \cdot 10^4$ . The results of the experiment show that it is possible to use an additional force driven by the Magnus effect that occurs when rotating cylinders with a horizontal axis. These results are considered useful for us in practice since these results can be used in combined wind engines operating at low wind speeds. This wind power plant can generate electricity starting from a wind speed of 2.8 m/s.

*Keywords:* Wind power plant, flow velocity, aerodynamic force, wind tunnel T-1-M, drag force, lifting force.

### Introduction

Energy is the basis of the climate problem and the key to solving it. A significant part of the greenhouse gases covering the Earth and trapping solar heat is generated during energy production when fossil fuels are burned to generate electricity and heat. Fossil fuels such as coal, oil, and gas are by far the biggest contributors to global climate change: they account for more than 75 percent of global greenhouse gas emissions and almost 90 percent of all carbon dioxide emissions.

Scientific evidence clearly shows that to avoid the worst effects of climate change, it is necessary to reduce emissions by almost half by 2030 and achieve net zero emissions by 2050.

To achieve this goal, we need to end our dependence on fossil fuels and invest in alternative energy sources that are clean, affordable, inexpensive, sustainable, and reliable.

Renewable energy sources, which are abundant around us thanks to the sun, wind, water, waste, and heat of the Earth, are replenished naturally and practically do not emit greenhouse gases or pollutants into the atmosphere.

Fossil fuels still account for more than 80 percent of global energy production, but cleaner energy sources are gradually gaining ground. Currently, about 20 percent of electricity comes from renewable sources [1].

Wind power is the most successful way out of the situation. The fact is that with the help of one or two wind turbines, it is possible to provide energy to the entire estate without creating a large network with a lot of expensive equipment [2]. As a result, there is a high demand for improving the operational reliability, availability, and performance of wind turbine systems [3].

There are many discoveries and works in the field of wind energy that many scientists around the world are doing.

One of them, the invention [4] is aimed at obtaining the maximum possible energy from the wind flow. The trailing edges of all aerodynamic wings move synchronously. Feature A wind turbine mounted on the main horizontal shaft has aerodynamic wings attached to rods and a mechanism for changing the angles of attack of the a-wings.

In [5], a mathematical model of a horizontal-axial wind power plant is considered, in the design of which Savonius rotors are used instead of classical blades. The Magnus force formed during the autorotation of the Savonius rotors creates a moment that supports the rotation of the central shaft of the turbine. The main difference between this work and previous studies in this area is that the change in the width of the blades along the radius is taken into account. At the same time, within the framework of the model, the conical Savonius rotor is replaced by a pair of cylindrical rotors of different diameters, which makes it possible to use experimental force-moment characteristics, taking into account a significant change in the velocity field along the radius of the blade. The model considers the possibility of controlling the value of the external electrical resistance in the local circuit of the generator of the installation.

The wind energy industry has been constantly updated in recent decades to explain the development of recent decades, it relies on an extensive dataset consisting of 35-year-old inventions of several megawatt wind turbines. According to forecasts, the size of onshore and offshore wind turbines will continue to increase, although, according to forecasts, the largest increase will occur with offshore wind turbines [6].

The article [7] also provides an overview of the most important and updated methods of condition monitoring based on non-destructive testing and methods applied to wind turbine blades. In addition, it analyzes future trends and problems related to systems for monitoring the condition of wind turbine blade structures.

In this regard, the experimental model proposed by us is a two-cylinder wind turbine with fixed blades.

At the D.A. Kunaev Institute of Mining, under the leadership of N.S. Buktukov, a promising design of the Buktukov wind farm was developed [8], in which the change in the area of the swept surface occurs not by shifting the half-cylinders, but by turning, which allows significantly increasing the power (many other domestic studies on the development of wind power plants were also studied in detail).

The aerodynamic element described in [9] was adopted as a prototype of the aerodynamic element that creates the Magnus effect on the wind turbine blades. The disadvantage of this wind turbine is the huge consumption of electricity for the operation of the drive.

A distinctive feature in this work from the previous ones is the mutual combination of two different blades (rotating cylinders and fixed blades), which ensures high aerodynamic quality of the wind turbine.

The purpose of the work is to analyze the aerodynamic characteristics of a two-bladed wind power plant containing combined power elements.

Based on the goal, the following tasks are set:

1. Investigation of aerodynamic forces depending on the flow velocity.
2. Analysis of the coefficients of lift and drag force from the Reynolds number for various variants of the location of the fixed blade relative to the cylinder.

#### *Experimental methodology*

Experiments were carried out in a wind tunnel, which is a channel in which an artificial airflow is created with the help of a fan.

A wind tunnel is an installation that creates a flow of air or gas for an experiment, studying the phenomena accompanying the flow of bodies. Experiments in a wind tunnel are based on the principle of reversibility of motion, according to which the movement of a body relative to air (or liquid) can be replaced by the movement of air running into a stationary body. To simulate the motion of a body in stationary air, it is necessary to create a uniform flow in a wind tunnel, having equal and parallel velocities at any point (a uniform velocity field), the same density, and temperature. Usually, in a wind tunnel, the flow around the model of the projected object or its parts is investigated and the forces acting on it are determined [10-12].

The T-1-M wind tunnel includes a working part, a diffuser, a fan, a transition channel, rotating blades, leveling grids, a pre-chamber, and a collector (nozzle) [13].

The main part of the T-1-M wind tunnel is its working part. The working part of the pipe is the place where the model of the test body is attached to the aerodynamic scales (Fig. 1). Especially serious requirements are imposed on the flow of the working part. The dimensions of the model should be smaller than the corresponding dimensions of the working part so that the flow boundaries do not affect the flow around the model [14].

The most accurate and reliable is the direct method of measuring forces and moments using aerodynamic scales. To measure the lifting force and drag force at different flow rates, three-component aerodynamic scales were used (Fig. 1). Measurements of air flow velocities were carried out by the Skywatch Atmos anemometer.

Figure 1 shows the appearance of a two-bladed layout with fixed blades and rotating cylinders with a diameter of 0.05 m.

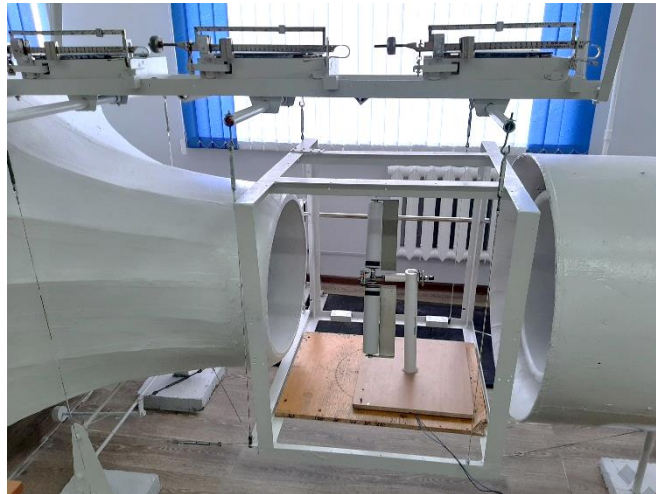
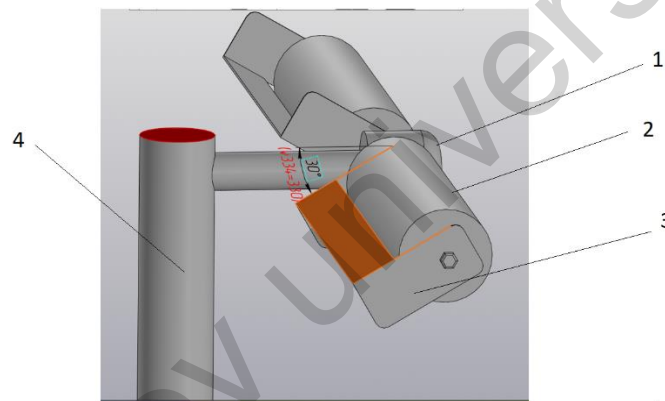

Figure 1. An experimental sample of a two-bladed layout



1 — generator, 2 — cylinder, 3 — fixed blade, 4 — mast

Figure 2. Schematic diagram of a wind turbine with fixed blades and rotating cylinders

The addition of rotating cylinders with fixed blades creates additional lifting force, which leads to an increase in the speed of rotation of the wind wheel.

The essence of this process lies in the fact that the fixed blade added to the rotating cylinder enhances the curvature of the profile of the wind-wheel blade. In this case, not only the curvature increases but also the immediate area of the blade. As a result of changes in these indicators, the flow pattern completely changes. These factors are decisive in increasing the lift coefficient.

In the frontal part of the blade to the point of separation of the boundary layer, there is a gradual delamination of experimental data for different elongations. With an increase in the length of the blade, the value of dimensionless pressure at a fixed angle decreases, a gradual transition from the pressure distribution characteristic of spatial motion — the flow around the cylinder and the fixed blade, to the pressure distribution characteristic of flat motion — the flow around an infinitely long cylinder.

A non-contact laser tachometer is used to measure the rotational speed.

In engineering practice, the formula is often used to calculate the lift coefficient:

$$C_y = \frac{\Delta F_y}{\rho \cdot \frac{u^2}{2} \cdot S} \quad \text{or} \quad C_y = \frac{2F_y}{\rho u^2 \cdot S}. \quad (1)$$

To calculate the drag coefficient  $C_x$  during the work, the following formula was used:

$$C_x = \frac{\Delta F_x}{\rho \cdot \frac{u^2}{2} \cdot S}, \text{ or } C_x = \frac{2F_x}{\rho u^2 \cdot S}. \tag{2}$$

Here  $\Delta F_x$  — drag force, [H];  $\Delta F_y$  — lifting force, [H];

$\rho$  — air density, [kg/m<sup>3</sup>];  $u$  — air flow rate, [m/s];  $S$  — midsection area, [m<sup>2</sup>].

To obtain universal dimensionless dependences in experiments, the Reynolds  $Re$  — the number is used as a dimensionless velocity, which characterizes the ratio of inertia forces to viscosity forces:

$$Re = \frac{u \cdot d_y}{\nu}, \tag{3}$$

where  $d_y$  — cylinder diameter, [m];  $\nu$  — kinematic viscosity of air, [m<sup>2</sup>/s].

Under experimental conditions, the values of air density and viscosity are equal, respectively:  $\rho = 1.21$  kg/m<sup>3</sup>,  $\nu = 1.49 \times 10^{-5}$  and m<sup>2</sup>/s.

### Research results

Figures 3 and 4 present the results of the experimental calculation of the lifting force and drag force from the flow velocity with different variants of the fixed blade relative to the cylinder.

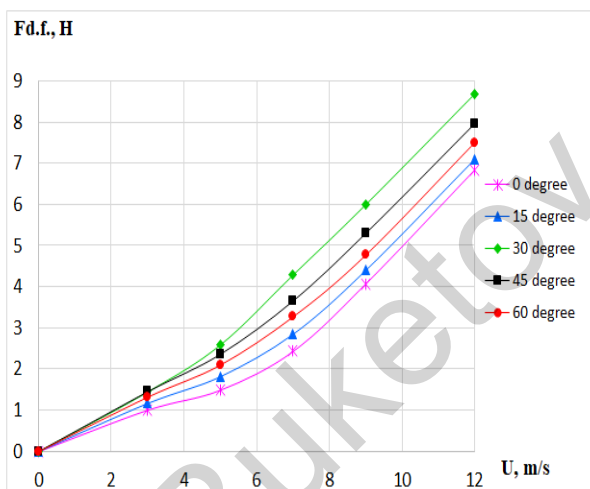

Figure 3. Graph of the dependence of drag forces on the flow velocity

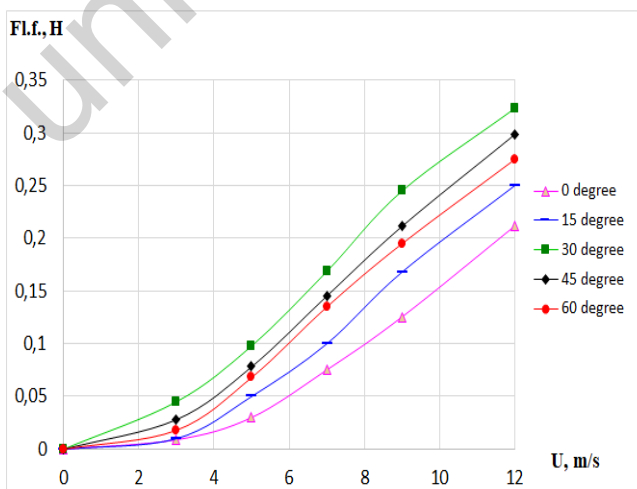

Figure 4. Graph of the dependence of the lifting force on the flow velocity

From the obtained dependences (Fig. 3-4), the proportional dependence of the lifting force and the drag force of the blades on the flow velocity is visible. From comparing the dependencies of a fixed blade relative to a cylinder with different angles  $\alpha$ , it is shown that the value of the lifting force of a wind turbine with fixed blades and rotating cylinders with an angle relative to the cylinder  $\alpha = 30^\circ$  is higher than that of the others.

This is explained by the fact that when deflecting with an angle  $\alpha = 30^\circ$  of the fixed blade, the lifting force increases due to an increase in the curvature of the profile.

Thus, fixed blades with an angle  $\alpha = 30^\circ$  relative to the cylinder have optimal aerodynamic characteristics.

Figures 5 and 6 show the dependences of the lift and drag coefficients on the Reynolds number for different variants of the fixed blade relative to the cylinder.

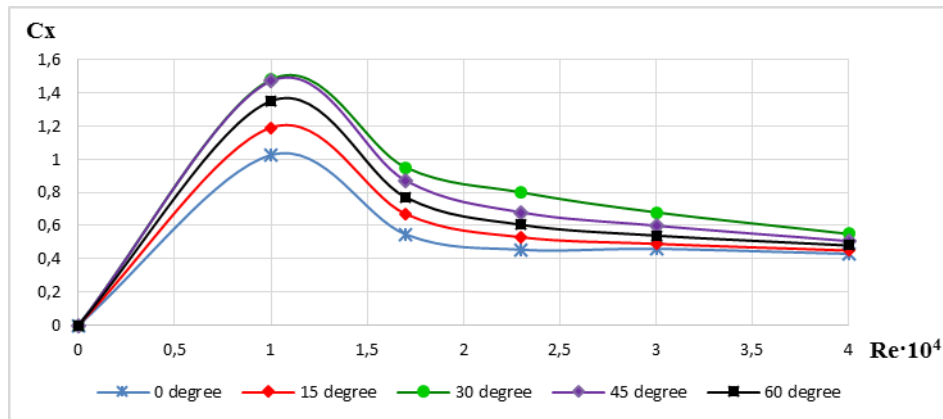

Figure 5. Dependence of the drag coefficient on the number of Re

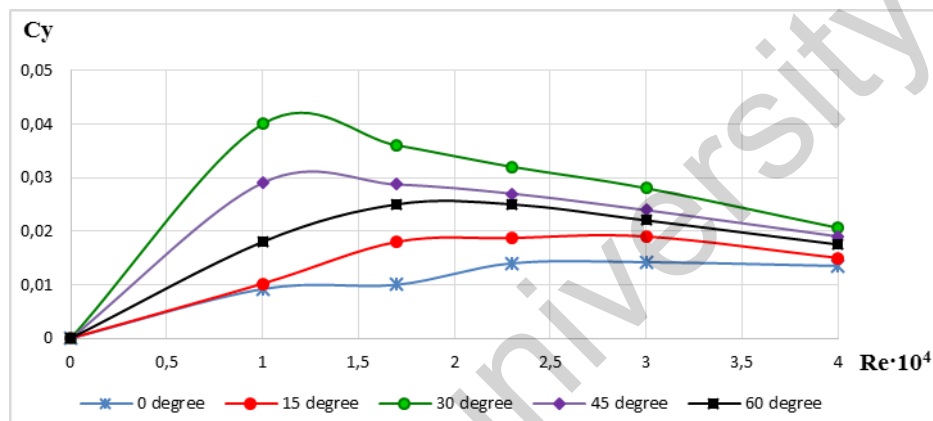

Figure 6. Dependence of the lift coefficient on the number of Re

As can be seen from Figures 5 and 6, when the fixed blade is positioned relative to the cylinder at 30 degrees, the optimal values of the lift and drag coefficients are obtained: 0.04 and 1.479 with a Reynolds number of  $1 \cdot 10^4$ . Compared with the other three samples at  $0^\circ$ ,  $15^\circ$ , and  $45^\circ$ , at  $60^\circ$ , the combined blade produces maximum drag force and minimum lift.

The rotating movements of the cylinders lead to the formation of a sufficiently voluminous vortex zone of reverse currents behind the cylinders, the dimensions of which depend on the speed of the incoming flow.

### Conclusion

In the course of the study, the following optimal results were obtained:

- It is established that the dependence of aerodynamic forces on the flow velocity for different variants of the fixed blade relative to the cylinder. It was found that at the maximum angle relative to the cylinder  $\alpha = 30^\circ$  that the value of the lifting force and the drag force of the fixed blade is higher than the rest. Based on this, it was found that at an angle  $\alpha = 30^\circ$  stationary, the blade has optimal aerodynamic characteristics;
- From the dependence of the coefficient of lift and drag force on the Reynolds number, it was found that at an angle of  $30^\circ$ , there is a minimum lifting force of 0.04 and a maximum drag force of 1.479 at  $Re = 1 \cdot 10^4$ .
- It was found that with the angle of the fixed blade of  $30^\circ$  degrees, the indicators of the entire combined blade are the most effective.
- It is determined that as a result of the interaction between the rotational movement of each cylinder and the stationary blade, a lifting force arises due to the Magnus effect, leading to the rotation of the horizontal shaft, which, in turn, drives the mechanism that generates electrical energy.

*The work was carried out with the financial support of the Science Committee of the Ministry of Science and Higher Education of the Republic of Kazakhstan (IRN AP14972704 "Numerical study of a new design of wind turbine blades with a horizontal axis of rotation").*

## References

- 1 Возобновляемая энергия — обеспечение более безопасного будущего. ООН. Меры по борьбе с изменением климата. — [Электронный ресурс]. — Режим доступа: <https://www.un.org/ru/climatechange/raising-ambition/renewable-energy#>
- 2 Альтернативные источники: энергия ветра, плюсы и минусы. — [Электронный ресурс]. — Режим доступа: <https://energo.house/veter/energiya-vetra.html>
- 3 Zhiwei G. An Overview on Fault Diagnosis, Prognosis and Resilient Control for Wind Turbine Systems / G. Zhiwei, L. Xiaoxu // MDPI Processes 2021, Vol. 9(2). — P. 300-319.
- 4 Патент РФ № RU 2692602 С 2. Экологичная и энергоэффективная ветротурбина на горизонтальном валу. Оpubл. 2019. Ю.Б. Соколовский, Д.Ю. Соколовский, А.Ю. Соколовский, О.Ю. Иванова.
- 5 Ишханян М.В. Ветротурбина класса «Савониус–Магнус» с коническими лопастями: динамика и управление / М.В. Ишханян, Л.А. Климина // Изв. РАН. Теория и системы управления. — 2020. — 4. — С. 160–168.
- 6 Peter E. Examining the trends of 35 years growth of key wind turbine components / E. Peter, X. George // Energy for Sustainable Development, 2019. — Vol 50. — P. 18-26.
- 7 Fausto P.M. A review of non-destructive testing on wind turbines blades / P.M. Fausto, M.C. Ana // Renewable Energy, 2020. Vol 161. P. 998-1010.
- 8 Буктуков Н.С. Ветроэлектростанция Буктукова 6 (варианты) / Н.С. Буктуков, Б.Ж. Буктуков, Г.Ж. Молдыбаева, А.К. Жакып // Оpubл. 18.12.2013 г. — Бюлл. — № 12. — 4 с.
- 9 Бычков Н.М. Ветродвижитель с эффектом Магнуса: 1 Результаты модельных исследований / Н.М. Бычков // Теплофизика и аэромеханика. — 2004. — Т. 11. — № 4. — С. 583–596.
- 10 Хозяинов Б.П. Методика проведения испытаний моделей ветроэнергетической установки в аэродинамической трубе 3–АТ–17.5/3 фирмы «УНИКОН» / Б.П. Хозяинов, М.А. Березин // Вестн. КузГТУ. — 2000. — № 4. — С. 38–42.
- 11 Верховский В.П. Газодинамическое проектирование профилированных сопел аэродинамических труб: дис. ... д-ра техн. наук: 01.02.05 — «Механика жидкости, газа и плазмы. Физико-математические науки» / В.П. Верховский // Центр. аэродинам. ин-т им. Н.Е. Жуковского. — М., 2005. — 250 с. — Инв. № 004410413.
- 12 Tleubergenova A.Zh. Study of aerodynamic parameters of the sail blade / A.Zh. Tleubergenova, N.K. Tanasheva, K.M. Shaimerdenova, L.L. Minkov, A.N. Dyusembayeva, S.Zh. Uzbergenova // Bulletin of the Karaganda university, Physics series, 2022. — Vol. 1(105) — P. 58-65.
- 13 Tanasheva N.K. Investigation of the aerodynamic forces of a triangular wind turbine blade for the low wind speeds / N.K. Tanasheva, A.Zh. Tleubergenova, K.M. Shaimerdenova, L.L. Minkov, S.Zh. Uzbergenova // Eurasian physical technical journal, 2021. — Vol. 4(38) — P. 59–64.
- 14 Гарипова Л.И. Определение аэродинамических характеристик модели несущего винта на режиме осевого обтекания / Л.И. Гарипова, А.С. Батраков, А.Н. Кусюмов, А.С. Михайлов, Дж. Баракос // Изв. вузов. Авиационная техника. — 2014. — № 3. — С. 7–13.

А.Ж. Тлеубергенова, А.Н. Дюсембаева, Н.К. Танашева, Ш.С. Кыздарбекова,  
А.Р. Мұхамедрахим

### **Біріктірілген күш элементтері бар екіқалақшалы жел энергетикалық қондырғысының аэродинамикалық сипаттамаларын талдау**

Мақалада әртүрлі параметрлердегі жел қондырғысының аэродинамикалық сипаттамалары зерттелген. Осы мақсатта қозғалмайтын қалақшаларымен екі цилиндрлі тәжірибелік үлгі жасалды. Қозғалмайтын қалақшаларымен және айналмалы цилиндрлері бар жел қондырғысының принципіальды сұлбесі алынды. Ауа ағынының жылдамдығы 3-тен 12 м/с-қа дейін өзгерді. Жел энергетикалық қондырғының аэродинамикалық күштерінің ағын жылдамдығына тәуелділігі зерттелді. Ауа ағынының жылдамдығынан жел қондырғысының цилиндріне қатысты қозғалмайтын қалақшаның орналасу  $\alpha$  бұрышын өзгерту бойынша эксперимент нәтижелеріне талдау жүргізілді. Қалақшаның орналасуы өзгерген кезде ауа ағынына қатысты маңдайлық кедергі өзгереді. Маңдайлық кедергі күші мен көтеру күштерінің ағын жылдамдығына тәуелділігі бойынша график салынды. Қозғалмайтын қалақшаның цилиндрге қатысты максималды  $\alpha=30^\circ$  бұрыш кезінде көтеру күші мен маңдайлық кедергі күшінің мәні жоғары екендігі анықталды. Маңдайлық кедергі күші мен көтеру күшінің коэффициентінің Рейнольдс санына тәуелділігінен  $30^\circ$  градус бұрышта минималды көтеру күші 0,04 және максималды маңдайлық кедергі күші 1,479 мәндері  $Re=1 \cdot 10^4$  кезінде болатындығы анықталды. Эксперимент нәтижелері көлденең осьті цилиндрлерді айналдыру кезінде пайда болатын, Магнус эффектісімен қозғалатын қосымша күш қолдануға болатындығын көрсетеді. Бұл нәтижелер іс жүзінде біз үшін пайдалы болып саналады, өйткені бұл нәтижелерді желдің төмен жылдамдығымен жұмыс істейтін біріктірілген жел қозғалқыштарында қолдануға болады. Осы жел қондырғысы 2,8 м/с жел жылдамдығынан бастап электр қуатын өндіре алады.

*Кілт сөздер:* жел энергетикалық қондырғы, ағын жылдамдығы, аэродинамикалық күш, Т-1-М аэродинамикалық құбыр, маңдайлық кедергі күші, көтеру күші.

А.Ж. Тлеубергенова, А.Н. Дюсембаева, Н.К. Танашева, Ш.С. Кыздарбекова,  
А.Р. Мухамедрахим

## Анализ аэродинамических характеристик двухлопастной ветроэнергетической установки, содержащей комбинированные силовые элементы

В статье изучены аэродинамические характеристики ветряной установки различных параметров. Для данной цели был изготовлен экспериментальный образец двухцилиндровый с неподвижными лопастями. Получена принципиальная схема ветроустановки с неподвижными лопастями и вращающимися цилиндрами. Скорость воздушного потока варьировалась, начиная от 3 до 12 м/с. Исследовалась зависимость аэродинамических сил ветроэнергетической установки от скорости потока. Проведен анализ результатов эксперимента по изменению угла  $\alpha$  расположения неподвижной лопасти относительно цилиндра от скорости воздушного потока ветряной установки. При изменении положения лопасти лобовое сопротивление меняется относительно воздушного потока. Построен график по зависимости сил лобового сопротивления и подъемной силы от скорости потока. Установлено, что при максимальном угле  $\alpha=30^\circ$  относительно цилиндра неподвижной лопасти значение подъемной силы и силы лобового сопротивления выше. Из зависимости коэффициента подъемной силы и силы лобового сопротивления от числа Рейнольдса определено, что при угле  $30^\circ$  градусов наблюдается минимальная подъемная сила 0,04 и максимальная сила лобового сопротивления 1,479 при  $Re=1 \cdot 10^4$ . Результаты эксперимента показывают, что можно использовать дополнительную силу, движимую эффектом Магнуса, возникающим при вращении цилиндров с горизонтальной осью. Эти результаты считаются полезными для нас на практике, поскольку они могут быть использованы в комбинированных ветряных двигателях, работающих при малых скоростях ветра. Эта ветроэнергетическая установка может вырабатывать электроэнергию, начиная со скорости ветра 2,8 м/с.

*Ключевые слова:* ветроэнергетическая установка, скорость потока, аэродинамическая сила, аэродинамическая труба Т–1–М, сила лобового сопротивления, подъемная сила.

### References

- 1 Vozobnovliaemaia energiia — obespechenie bolee bezopasnogo budushchego. OON. Mery po borbe s izmeneniem klimata [Renewable energy — ensuring a safer future. UN. Measures to combat climate change]. (n.d.). *base.garant.ru*. Retrieved from <https://www.un.org/ru/climatechange/raising-ambition/renewable-energy#> [in Russian].
- 2 Alternativnye istochniki: energiia vetra, pliusy i minusy [Alternative sources: wind energy, pros and cons]. (n.d.). *base.garant.ru*. Retrieved from <https://energo.house/veter/energiya-vetra.html> [in Russian].
- 3 Zhiwei, G., & Xiaoxu, L. (2021). An Overview on Fault Diagnosis, Prognosis and Resilient Control for Wind Turbine Systems. *MDPI Processes*, 9(2), 300–319.
- 4 Sokolovskii, Yu.B., Sokolovskii, D.Yu., Sokolovskii, A.Yu., & Ivanova, O.Yu. (2018). Patent Rossiiskoi Federatsii No RU 2692602 C 2. Ekologichnaia i energoeffektivnaia vetroturbina na gorizontalnnoe valu [Patent of Russian Federation No RU 2692602 C2. Eco-friendly and energy-efficient wind turbine on a horizontal shaft] [in Russian].
- 5 Iskhanian, M.V., & Klimina, L.A. (2020). Vetroturbina klassa «Savonius–Magnus» s konicheskimi lopastiami: dinamika i upravlenie [“Savonius–Magnus” class wind turbine with conical blades: dynamics and control]. *Izvestiia Rossiiskoi akademii nauk. Teoriia i systemy upravleniia — Proceedings of the Russian Academy of Sciences. Theory and control systems*, 8, 160–168 [in Russian].
- 6 Peter, E., & George, X. (2019). Examining the trends of 35 years growth of key wind turbine components. *Energy for Sustainable Development*, 50, 18–26.
- 7 Fausto, P.M., & Ana, M.C. (2020). A review of non-destructive testing on wind turbine blades. *Renewable Energy*, 161, 998–1010.
- 8 Buktukov, N.S., Buktukov, B.Zh., Moldybaeva, G.Zh., & Zhakyp, A.K. (2013). Vetroelektrostantsiia Buktukova 6 (varianty) [Wind farm of Butukova 6 (options)]. No. 12, 4 p. [in Russian].
- 9 Bychkov, N.M. (2004). Vetrodvigatel s efektom Magnusa: 1 Rezultaty modelnykh issledovaniy [Wind turbine with Magnus effect: 1 Results of model studies]. *Thermophysics and aeromechanics — Thermophysics and Aeromechanics*, 11(4), 583–596 [in Russian].
- 10 Hozjainov, B.P., & Berezin, M.A. (2000). Metodika provedeniia ispytaniy modelei vetroenergeticheskoi ustanovki v aerodinamicheskoi trube 3–AT–17.5/3 firmy «UNIKON» [The methodology of testing wind power plant models in the wind tunnel]

3–AT–17.5/3 of the company UNICON]. *Vestnik Kuzbasskogo gosudarstvennogo tekhnicheskogo universiteta — Bulletin of the Kuzbass State Technical University*, 4, 38–42 [in Russian].

11 Verhovskii, V.P. (2005). *Gazodinamicheskoe proektirovanie profilirovannykh sopel aerodinamicheskikh trub* [Gas-dynamic design of profiled wind tunnel nozzles]. *Tsentralnyi aerodinamicheskii institut imeni N.E. Zhukovskogo — Centre Aerodynamic Institute named after N.E. Zhukovsky. Doctor`s thesis*. Moscow [in Russian].

12 Tleubergenova, A.Zh., Tanasheva, N.K., Shaimerdenova, K.M., Minkov, L.L., Dyusembaeva, A.N., & Uzbergenova, S.Zh. (2022). Study of aerodynamic parameters of the sail blade. *Bulletin of the Karaganda University, Physics series*, 1(105), 58-65.

13 Tanasheva, N.K., Tleubergenova, A.Zh., Shaimerdenova, K.M., Minkov, L.L., & Uzbergenova, S.Zh. (2021). Investigation of the aerodynamic forces of a triangular wind turbine blade for the low wind speeds. *Eurasian Physical Technical Journal*, 4(38), 59-64.

14 Garipova, L.I., Batrakov, A.S., Kusiumov, A.N., Mihailov, A.S., & Barakos, Dzh. (2014). *Opredelenie aerodinamicheskikh kharakteristik modeli nesushchego vinta na rezhime oseвого obtekaniia* [Determination of aerodynamic characteristics of the main rotor model in axial flow mode]. *Izvestiia vuzov. Aviatsionnaia tekhnika — News of universities. Aviation equipment*, 3, 7–13 [in Russian].

Buketov university