



Received: 30/07/2024

Revised: 23/12/2024

Accepted: 18/03/2025

Published online: 31/03/2025

Research Article



Open Access under the CC BY -NC-ND 4.0 license

UDC 537.322

DETECTION ALGORITHM FOR FAULTY CONTACT JOINTS IN ELECTRICAL NETWORK

Soldatov A.I.¹, Soldatov A.A.¹, Kostina M.A.¹, Abouellail A.A.², Bortalevich S.I.³¹ Tomsk State University of Control Systems and Radioelectronics, Tomsk, Russia,² Sphinx University, New Asyut, Egypt,³ Market Economy Institute, Russian Academy of Sciences, Moscow, Russia*Corresponding author: mariyakostina91@mail.ru

Abstract. The article proposes a thermoelectric method for monitoring the contact resistance of contact joints in power grids. It describes an algorithm to detect faulty contact joints with resistance exceeding the value specified in regulatory standards. The algorithm is considered using the example of a circuit containing five contact joints and three electrical installations. The algorithm is based on calculating contact resistance from the measured values of thermoelectromotive force and flowing current only at the moment the electrical installation is turned on, which makes it possible to calculate the resistance of the contact through which the electrical installation is connected. By the number of electrical installations being turned on or off, the numbers of the contact joints that make up the power supply circuit of this installation are determined.

Keywords: contact joint, power supply network, thermoelectromotive force, algorithm.

1. Introduction

Power grids are integral to any technological process, where electricity is supplied to consumers via networks of power lines, whose length may reach thousands of kilometers. This creates certain complications due to conductor connections, which become inevitable. There are two types of connections: detachable and permanent. Permanent connections include crimping, soldering, and welding. Detachable connections include twisting, bolted connection, terminal block connection, plug-socket connection, etc. When operating such connections, malfunctions may occur in the form of high electrical contact resistance (ECR), which is one of the main causes of fires in electrical installations. The number of fires that occurred as a result of violations of the rules for operating electrical equipment is steadily increasing. Thus, in Russia, for instance, the number of fires increased from 41,317 in 2016 to 51,930 in 2021 [1]. The death toll was 2,289 people in 2021 alone, and the number of injured was 2,545. The material damage caused amounted to over 15 billion Russian Rubles [2]. A similar trend is observed in America, where the number of fires caused by faulty electrical installations in the residential sector alone increased from 43.5 thousand in 2016 to 48.4 thousand in 2021 [3]. In 2019 alone, property damage amounted to about \$15 billion [4]. One of the causes of fires in electrical installations is the ignition of contact joints due to increased contact resistance, which leads to excessive heating. The value of contact resistance is regulated by documents RD 34.45-51.300-97 and PTEEP and should not exceed 0.05 Ohm. For explosive premises, the contact resistance should not exceed 0.03 Ohm. The reasons for high ECR occurrence have been investigated [5-9], and various methods to reduce it have been proposed and

developed in recent years [10-15]. However, none of these approaches meet modern requirements for monitoring contact resistance or allow monitoring during the operation of electrical installations.

2. Problem Specification

To control the ECR value of a contact joint, the authors proposed using the thermoelectric method [16-19], which consists in the appearance of a thermoEMF signal in contact pairs of dissimilar conductors, due to an increase in temperature when the load current flows through the contact resistance.

It should be noted that the thermoelectric method has not been used previously to monitor contact resistance and was proposed by the authors for the first time. The thermoelectric method is traditionally used to sort finished products by grades of steels and alloys, to testing the quality of heat treatment, to testing the quality of electron beam welding, to testing plastic deformation and to measure temperature [20-23]. More recently, it has been used to monitoring the thermal resistance of the contact pair transistor housing-cooling radiator [24]. Laboratory tests confirmed the feasibility of using the thermoelectric method for real-time monitoring of contact resistance in live power supply networks [17].

However, the power supply system of even one room contains several contact joints, and the appearance of a thermoEMF signal in the power supply network does not allow one to unambiguously determine a faulty contact joint.

It is not economically feasible to use a thermoelectric monitoring device on each contact joints to monitor its resistance, in addition, as a rule, most contact joints that make up the power supply circuit of an electrical installation are located in hard-to-reach places: in distribution boxes, in hidden channels of wall panels, etc., so connecting a contact resistance monitoring device to these contact joints is extremely difficult. A possible solution to this problem would be to use one thermoelectric monitoring device to monitor a group of contact joints. The purpose of this study is to develop a method for detecting faulty contact joints among those being monitored in a power supply network, using one thermoelectric monitoring device. Considering that the thermoelectric monitoring method is used for the first time to monitor the resistance of a contact joint, there are currently no methods for detecting faulty contact joints.

3. Problem-Solving Approach

To detect the contact resistance of the contact joints, the moment of switching on and the number of the electrical installation (loads) are determined by the presence of current flowing through this electrical installation, the obtained data about the switched-on electrical installation and the amount of flowing current is transferred to the microcontroller, and the change in thermoEMF is analyzed when each electrical installation is turned on and off. By the number of the electrical installation being turned on or off, the numbers of the contact joints that make up the power supply circuit of this installation are determined. For example, consider the power supply circuit of three electrical installations with a system for monitoring the contact resistance of the contact joints (Fig. 1).

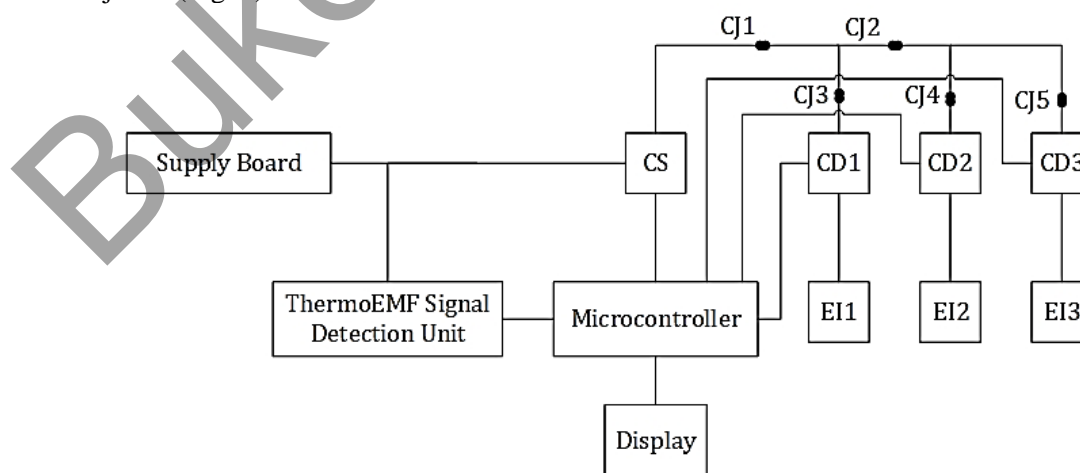

Fig.1. Power supply diagram of three electrical installations with a contact resistance monitoring system

The circuit contains an input panel, a current sensor (CS), contact joints CJ1...CJ5, current detectors CD1...CD3, three electrical installations EI1, EI2 and EI3, a thermoEMF signal detection unit, a microcontroller and a display. The first electrical installation is connected to the input panel through a current sensor (CS), contact joints CJ1 and CJ3, and a current detector CD1. The second electrical installation is connected to the input panel through a current sensor (CS), contact joints CJ1, CJ2, and CJ4, and a current detector CD2. The third electrical installation is connected to the input panel through a current sensor (CS), contact joints CJ1 and CJ5, and a current detector CD3.

When the first electrical installation is turned on, current flows through the current sensor (CS), contact joints CJ1 and CJ2, current detector CD1, and the first electrical installation. The thermoEMF signal detection unit separates the thermoEMF signal from the total signal of the power supply network and transmits it to the microcontroller. The microcontroller reads this signal only when the first electrical installation starts. The moment the electrical installation is turned on is determined by the start of current flow detected by the current detector CD1. The microcontroller also receives data from the current sensor. The microcontroller determines the current flowing through the first electrical installation by subtracting the current before switching on from the current after switching on. The resulting value is stored in the memory of the microcontroller. A similar procedure is carried out when turning off the first electrical installation. Based on the received data on the current value and thermoEMF, the microcontroller calculates the contact resistance. Since the first electrical installation is connected to the input panel through two contact joints CJ1 and CJ3, two options are possible: first - only the current of the first electrical installation flows through the contact joints CJ1, i.e. the second and third electrical installations are not turned on. In this case, the microcontroller can only calculate the total resistance of the two contact joints. In the second case, the second or third electrical installation, or both together, may be turned on. In this case, the resistance of the contact joint CJ1 does not affect the value of thermoEMF and the microcontroller calculates the resistance of the contact joint CJ3.

When the second electrical installation is turned on, current flows through the current sensor (CS), contact joints CJ1, CJ2, CJ4, current detector CD2 and the second electrical installation. The thermoEMF signal detection unit separates the thermoEMF signal from the total signal of the power supply network and transmits it to the microcontroller. The microcontroller reads this signal only when the second electrical installation starts. The moment the electrical installation is turned on is determined by the start of current flow detected by the current detector CD2. The microcontroller also receives data from the current sensor. The microcontroller determines the current flowing through the second electrical installation by subtracting the current before switching on from the current after switching on. Considering the fact that the second electrical installation is connected to the input panel through the contact joints CJ1, CJ2, and CJ4, four options are possible for calculating the contact resistance. First case: only the second electrical installation is turned on. In this case, the microcontroller can only calculate the total resistance of the three contact joints. The second case is when the first electrical installation is turned on. In this case, the total resistance of the contact joints CJ2 and CJ4 is calculated. The third case is when the third electrical installation is turned on. In this case, the resistance of the contact joint CJ4 is calculated. Fourth case: the first and third electrical installations are turned on. In this case, the resistance of the contact joint CJ4 is calculated. The resulting value is stored in the memory of the microcontroller. A similar procedure is carried out when turning off the second electrical installation.

When the third electrical installation is turned on, current flows through the current sensor (CS), contact joints CJ1, CJ2, and CJ5, current detector CD3 and the third electrical installation. The thermoEMF signal detection unit separates the thermoEMF signal from the total signal of the power supply network and transmits it to the microcontroller. The microcontroller reads this signal only when the third electrical installation starts. The moment of switching on the third electrical installation is determined by the start of current flow detected by the current detector CD3. The microcontroller also receives data from the current sensor. The microcontroller determines the current flowing through the third electrical installation by subtracting the current before switching on from the current after switching on. Taking into account the fact that the third electrical installation is connected to the input panel through the contact joints CJ1, CJ2, and CJ5, four options are possible for calculating the contact resistance. First case: the first and second electrical installations are not turned on. In this case, the total resistance of the three contact joints CJ1, CJ2 and CJ5 is calculated. Second case: the first electrical installation is turned on. In this case, the total resistance of the two contact joints CJ2 and CJ5 is calculated. The third case is when the second electrical installation is turned on. In this case, the resistance of the contact joint CJ5 is calculated. Fourth case: the first and second electrical installations are

turned on. In this case, the resistance of the contact joint CJ5 is calculated. The resulting value is stored in the memory of the microcontroller. A similar procedure is carried out when turning off the second electrical installation. The operating algorithm of the contact joint resistance monitoring system is presented in Fig. 2.

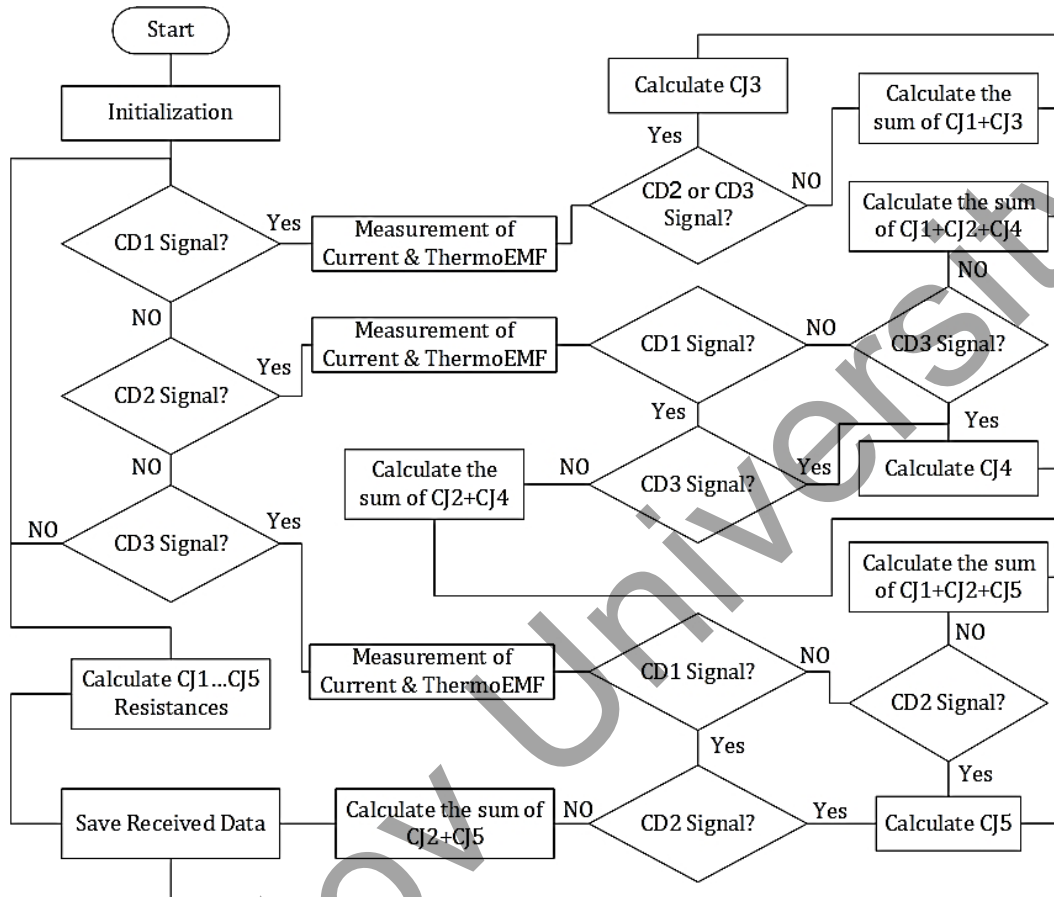

Fig.2. Algorithm of operation of the contact-joint resistance monitoring system

The process of calculating the resistances of contact joints CJ1, CJ2, CJ3, CJ4, and CJ5 from the obtained data includes solving several equations. When the first electrical installation is turned on and the second and/or third are turned on, the contact resistance of CJ3 is determined. When the second electrical installation is turned on and the first and/or third are turned on, the contact resistance of CJ4 is calculated. When the third electrical installation is turned on and the first and/or second are turned on, the contact resistance of CJ5 is calculated. For other combinations of switching on electrical installations, the total resistance of several contacts is calculated, and then the unknown contact resistance is calculated, for example:

$$R_{CJ1} = (R_{CJ1} + R_{CJ3}) - R_{CJ3}$$

$$R_{CJ2} = (R_{CJ2} + R_{CJ4}) - R_{CJ4}$$

For a different wiring diagram for electrical installations, the algorithm is written similarly, considering the presence of specific contact joints. The method for calculating contact resistance was described in detail by the authors [17], where the following expression was obtained for calculating contact resistance from the measured values of thermoEMF and current flowing through the contact joint:

$$R = \frac{K \cdot S \cdot \frac{E}{(S_1 - S_2)}}{I^2} \quad (1)$$

where E is the thermoEMF value, S_1 and S_2 are the Seebeck coefficients of the contact pair, I is the current through the contact pair, K is the general heat transfer coefficient, taking into account all its types; S – contact cooling surface area.

4. Experimental Procedure

A practical test of the algorithm's operation was carried out on a device prototype (Fig. 3).

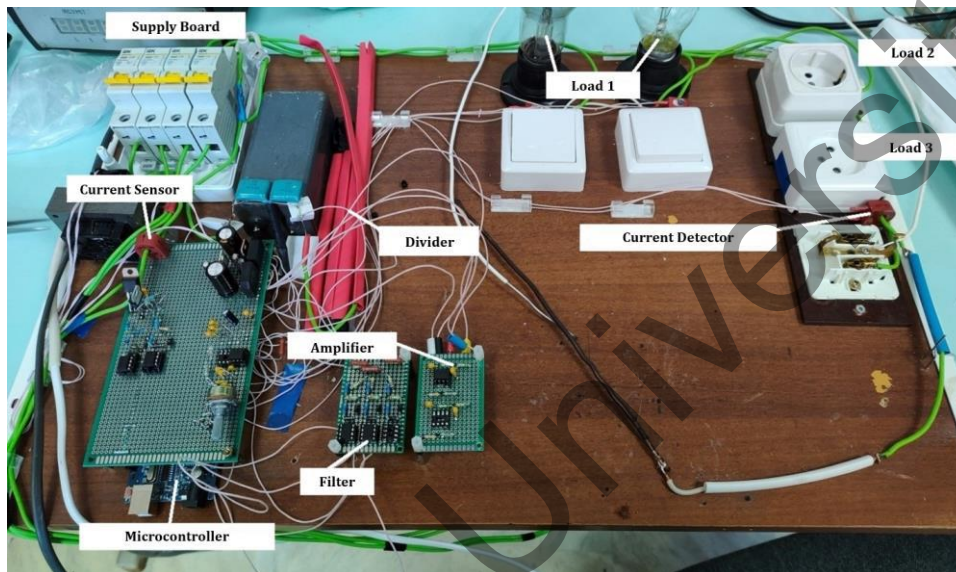

Fig.3. Experimental model of the contact joint resistance monitoring system

The layout contains an input panel, three electrical installations (loads): two incandescent lamps (load 1 with a contact joint in the form of a switch (CJ3)) and two sockets (Cariva 773659 from Legrand) for connecting an electric kettle and an iron (load 2 (CJ4) and load 3 (CJ5)), a current detector, current sensor (ACS758LCB-100B from Allegro), microcontroller, thermoEMF signal detection unit, including a divider, filter and amplifier. Also, two contact joints, CJ1 and CJ2, were artificially introduced in the form of twisting two conductors made of copper and aluminum to correspond to the structural diagram shown in Fig. 1. To increase the contact resistance of CJ1, it was placed in a heat chamber and heated at a temperature of 150 °C for 20 hours. At the same time, an oxide film formed on the surface of the copper conductor and the contact resistance became about 0.4 Ohm. The measurement was carried out with a Rigol DM3068 multimeter. When three electrical installations were turned on and off sequentially, the monitoring system detected the first contact joint CJ1 with a resistance exceeding the permissible value of 0.05 Ohm.

5. Results and Discussion

The presented example, which involves detecting the resistance of contact joints in three electrical installations connected to the power grid via five contact joints, demonstrates a general approach to developing an algorithm for detecting a faulty contact joint. For each room, such an algorithm will be unique, in which it is necessary to take into account the number of electrical installations, the number of contact joints used to connect each electrical installation to the input panel, the number of common contact joints for all electrical installations, the number of common contact joints for several electrical installations. For the system to accurately detect faulty connections, each installation needs a current alarm to pinpoint switching events. These events are crucial because they induce thermoEMF changes in the connecting joints. ThermoEMF changes at other times are likely to be due to switching activity in other installations. Crucially, precise faulty joints detection requires knowledge of the Seebeck coefficient of the metals used in the contact joints.

6. Conclusion

The use of the proposed algorithm for detecting a faulty contact joint in the presented example of a power supply network can be implemented in continuous monitoring of contact joints in the power supply network of an office building or other separate premises. Timely detection of a faulty contact joint will eliminate failures in power grids, ensure trouble-free operation of electrical equipment, eliminate the fire hazard of contact joints, and thereby prevent man-made accidents. The article discusses a general approach to developing an algorithm for monitoring a faulty contact joint. For a specific power supply network, it is necessary to develop a specified algorithm for detecting a faulty contact joint based on the approach proposed by the authors.

Conflict of interest statement

The authors declare that they have no conflict of interest in relation to this research, whether financial, personal, authorship or otherwise, that could affect the research and its results presented in this paper.

CRedit author statement

Kostina M.A.: Formal analysis, Data Curation; **Soldatov A.I.:** Conceptualization, Methodology, Project administration; **Soldatov A.A.:** Investigation, Validation; **Abouellail A.A.:** Software; **Bortalevich S.I.:** Resources. The final manuscript was read and approved by all authors.

References

- 1 Pronin S.V. (2021) Analysis of statistical data on fires resulting from emergency operating modes of electrical equipment. *Actual Research*, 38 (65). 11-14. [in Russian]. Available at: <https://apni.ru/article/2930-analiz-pozharov-po-prichinam-svyazannim>.
- 2 Chechetkina T.A., Goncharenko V.S., Sibirko V.I., Zagumennova M.V. (2022) The situation with fires in the Russian Federation in 2021. *Fire safety*, 1 (106). 98-115. [in Russian] Available at: https://elibrary.ru/download/elibrary_48100502_59795205.pdf.
- 3 Residential Building Fire Causes (2013-2022). Available at: <https://www.usfa.fema.gov/statistics/residential-fires/causes.html> (Jan22, 2020).
- 4 U.S. Fire Statistics. Available at: <https://www.usfa.fema.gov/statistics/data-sets/> (Dec16, 2023).
- 5 Titkov V.V., Bekbaev A.B., Sarsenbaev E.A. (2017) On the possibilities of monitoring non-stationary thermal processes in the contacts of power electrical installations. *Scientific and Technical Bulletin of SPbPU. Natural and engineering sciences*, 23(1). 168-178. [in Russian] Available at: https://engtech.spbstu.ru/userfiles/files/articles/2017/1/16_titkov.pdf.
- 6 Chaly A.M., Dmitriev V.A., Pavleino M.A., Pavleino O.M. (2013) Heating of high-current electrical contacts by short-circuit shock currents. *Electronic processing of materials*, 49(5). 81–88. [in Russian] Available at: <https://cyberleninka.ru/article/n/nagrev-silnotochnyh-elektricheskikh-kontaktov-udarnymi-tokami-korotkogo-zamykaniya>
- 7 Chaly A.M., Dmitriev V.A., Pavleino M.A., Pavleino O.M., Safonov M.S. (2016) On the peculiarities of welding and destruction of the surface of high-current contacts by pulsed currents. *Electronic processing of materials*. 52(6). 12-18. [in Russian] Available at: <https://cyberleninka.ru/article/n/ob-osobennostyah-svarivaniya-i-razrusheniya-poverhnosti-silnotochnyh-sloistyh-kontaktov-impulsnymi-tokami/viewer>
- 8 Troitskiy O.A., Stashenko V.I., Skvortsov O.B. (2018) Vibrations of conductors during transmission of pulsed electric current and non-destructive testing. *Engineering Journal: Science and innovation electronic scientific and technical publication*. 3. 1-16. [in Russian] Available at: <https://doi.org/10.18698/2308-6033-2018-3-1741>
- 9 Chuprova L.V., Ershova O.V., Mullina E.R. (2013) Chemical and technological aspects of the problem of oxidation of copper contacts of electrical equipment operated in water purification workshops. *Young Scientist*, 9 (56). 77-80. [in Russian] Available at: <https://moluch.ru/archive/56/7712/>
- 10 Wang J., Wu Z., Mao C., Zhao Y., Yang J., Chen Y. (2018) Effect of electrical contact resistance on measurement of thermal conductivity and wiedemann-franz law for individual metallic nanowires. *Scientific Reports*, 8(4862). <https://doi.org/10.1038/s41598-018-23291-9>
- 11 Ren W., Chen Y., Cao S., Cui L., Liang H. (2013) A new automated test equipment for measuring electrical contact resistance of real size rivets. *Holm*, 1-7. <https://doi.org/10.1109/HOLM.2013.6651396>.
- 12 Mozgalin N.F. (2010) Electrically conductive lubricants – a reliable measure to reduce the emergency in networks and reduce losses in electrical contacts. *Industrial power engineering*, 11. 13-16. [in Russian] Available at: <https://elibrary.ru/item.asp?id=20600601>

- 13 Belyaev V.L., Shalaginov A.A. (2014) Investigation of the effect of electrically conductive lubricants on the resistance of high-current contact systems of electrolyzers and electrical apparatus. *Industrial power engineering*, 5. 34-37. [in Russian] Available at: https://labhcs.narod.ru/prom_energetika5-2014.pdf
- 14 Sivkov A.A., Shanenkova Y.L., Saygash A.S., Shanenkov I.I. (2016) High-speed thermal plasma deposition of copper coating on aluminum surface with strong substrate adhesion and low transient resistivity. *Surface and Coatings Technology*, 292. 63-71. <https://doi.org/10.1016/j.surfcoat.2016.03.029>
- 15 Sivkov A.A., Saigash A.S., Kolganova Yu.L. (2013) The influence of the properties of a copper coating on an aluminum contact surface on the transient resistance. *Electrical engineering*, 8. 11-14. [in Russian] Available at: https://elibrary.ru/download/elibrary_19405835_44481637.pdf.
- 16 Soldatov A.I., Soldatov A.A., Kostina M.A., Bortalevich S.I., Loginov E.L. (2018) Method of non-destructive testing of faults in the electrical network. Patent of the Russian Federation No.2656128. [in Russian] Available at: https://elibrary.ru/download/elibrary_37372302_67574899.PDF.
- 17 Abouellail A.A., Chang T., Soldatov A.I., Soldatov, Soldatov, A.A., Kostina M., Bortalevich S. (2022) Laboratory substantiation of thermoelectric method for monitoring contact resistance. *Russian Journal of Nondestructive Testing*, 58(12). 1153-1161. <https://doi.org/10.1134/S1061830922700152>
- 18 Obach I.I., Abouellail A.A., Soldatov A.I., Soldatov A.A., Sorokin P.V., Shinyakov Y.A., Sukhorukov M.P. (2019) Monitoring of power supply. *SIBCON 2019 - Proceedings*. 8729572. <https://doi.org/10.1109/SIBCON.2019.8729572>
- 19 Obach I.I., Soldatov A.A. (2018) Monitoring of the electric network using a thermoelectric component. *Collection of selected articles of the scientific session of TUSUR*. 1-2. 60-62. [in Russian] Available at: https://elibrary.ru/download/elibrary_36415407_25063302.pdf.
- 20 Carreon H. (2000) Thermoelectric detection of spherical tin inclusions in copper by magnetic sensing. *Journal of Applied Physics*, 88(11). 6495. <https://doi.org/10.1063/1.1322591>
- 21 Nagy P.B. (2010) Non-destructive methods for materials' state awareness monitoring. *Insight: Non-Destructive Testing and Condition Monitoring*, 52(2). 61-71. <https://doi.org/10.1784/insi.2010.52.2.61>
- 22 Li J.F., Liu W.S., Zhao L.D., Zhou M. (2010) High-performance nanostructured thermoelectric materials. *Npg Asia Mater.*, 2(4). 152-158. <https://doi.org/10.1038/asiamat.2010.138>
- 23 Carreon H., Medina A. (2007) Nondestructive characterization of the level of plastic deformation by thermoelectric power measurements in cold-rolled Ti-6Al-4V samples. *Materials Science, Nondestructive Testing and Evaluation*, 299-311. <https://doi.org/10.1080/10589750701546960>
- 24 Abouellail A.A., Chang J., Soldatov A.I., Soldatov A.A., Kostina M.A., Vasiliev I.M. (2023) Thermoelectric monitoring of thermal resistance in electronic systems. *Eurasian Physical Technical Journal*, 20(3(45)) 52-61. <https://doi.org/10.31489/2023No3/52-61>

AUTHORS' INFORMATION

Soldatov, A.A. – Candidate of techn. sciences, Associate Professor, Tomsk State University of Control Systems and Radioelectronics, Tomsk, Russia; <https://orcid.org/0000-0003-0696-716X>; soldatov.88@bk.ru

Soldatov, A.I. – Doctor of techn. sciences, Professor, Tomsk State University of Control Systems and Radioelectronics, Tomsk, Russia, Tomsk, Russia; <https://orcid.org/0000-0003-1892-1644>; asoldatof@mail.ru

Kostina, M.A. – Candidate of techn. sciences, Associate Professor, Tomsk State University of Control Systems and Radioelectronics, Tomsk, Russia; <https://orcid.org/0000-0003-2626-6002>; mariyakostina91@mail.ru

Abouellail, A.A. - Candidate of techn. sciences, Lecturer, Sphinx University, New Asyut, Egypt; <https://orcid.org/0000-0002-9357-6214>; ahmed.abouellail@sphinx.edu.eg

Bortalevich S.I. - Doctor of econ. sciences, Professor, Market Economy Institute, Russian Academy of Sciences, Moscow, Russia; <https://orcid.org/0000-0002-2978-7797>; 680097@inbox.ru