

DOI 10.31489/2023No4/81-89

UDC 53.072; 681.5.075

STUDYING THE PHYSICAL CHARACTERISTICS OF THE SNAKE ROBOT MOTION BASED ON THE “BIOLOID PREMIUM KIT” CONSTRUCTION

Loboda Yu.¹, Galtseva O.^{1,2}, Biryukova N.¹¹ Tomsk State University of Control Systems and Radioelectronics, Tomsk, Russia² National Research Tomsk Polytechnic University, Tomsk, Russia

This article examines the physical characteristics of the movement of a snake robot. The main purpose of this work is to develop an algorithm based on the study of the physical characteristics of the movement of a snake robot, which will allow movement in various environmental conditions, both an industrial robot manipulator and a mobile robot. In the course of the work, the equations of motion of the snake robot on various surfaces were obtained. It is established that the snake robot is an open kinematic chain, the elements of which are interconnected by five or more kinematic nodes of rotation based on solving direct and inverse kinematics problems and calculating the position of the robot block in a given orientation. Based on the study of the physical movements of snakes, a proprietary algorithm for the movement of a snake robot has been developed. A prototype snake robot based on the ROBOTIS BIOLOID Premium Kit was assembled and tested on seven different surfaces. The created high-speed prototype consists of eleven blocks and a CM-530 controller without wheels and ensures high smoothness of movement compared to analogues thanks to the use of the developed algorithm.

Keywords: snake robot algorithm, snake movement, serpentine robot, physical characteristics, control, RoboPlus.

1. Introduction

Useful characteristics of snake-like robots (stability, permeability, good adhesion to the surface) allow them to move easily in unpredictable conditions that are problematic for traditional wheeled or humanoid robots. The snake can distribute the weight of its body over a large area at the risk of subsidence of the ground; the snake robot can continue to move even when a part of the ground falls or hangs in the air. The authors see the following possibilities of using a snake robot, based on this.

Such a robot can also be used as an in-line flaw detector to check the condition of the walls of main pipelines without opening it in the oil and gas industry [1]. Snake robots could solve the problem of laying cables and electrical equipment lines in a wall or in a pipe, as well as at various distances [2-3]. It is also possible to use serpentine robots in minimally invasive surgery to eliminate the need to make large incisions in the skin and body tissues. When the size of the wound decreases, it is less traumatic for the body, resulting in an easier postoperative period, a reduction in the cost of postoperative care, etc. [4].

In addition, coil robots can manifest themselves in the best way in areas of natural disasters, be it earthquakes, landslides, explosions, hurricanes, fires. The ability to control a small mobile device with a camera and microphone opens up attractive opportunities for law enforcement agencies. If necessary, the robot can work in the autumn-spring period as a lifeguard on ice river crossings [5]. Many tracked and wheeled vehicles (at movement limitation of them) are used in conditions where human activity is unsafe, for example, where there is a danger of radiation, temperature restrictions, chemical toxicity, pressure, weakening of structures, etc. Snake-like robots are devoid of many disadvantage characteristics of wheeled structures [6].

The movement of the robot with the help of wheels is easier to understand than with the help of the musculoskeletal system; the movement of the snake is not so obvious at the same time. It is the understanding of the laws of motion when modeling a snake robot that will help to apply widely this robot in various fields. One of the main issues in the modeling of serpentine robots is their management. Servo engines fixed on special units are used in this snake. It allows the robot to move according to almost any algorithm, similar to the real snake motion. The robot possesses a camera taking the picture in the FullHD format (standard in accordance with matrix resolution 1920×1080 pixels), as well as a number of sensors,

which make it possible to orientate. The fastest natural snakes can move with the speed 3m/s in ideal conditions. It seems unlikely that robotic systems will move with the same speed in the nearest future as the majority of snakes move rather slow. Feedback control approach is used in the servo-engines Dinamixel AX-12A, due to this high accuracy of positioning has been achieved. One of the main questions under modeling serpentine robots is a control by them. Motion of robot using wheels is easier to understand than that by locomotor system; wherein, the snake motion is not so obvious. As it is known, a snake body is rather long and can consist of 200÷400 spinal bones [7]. This provides multitude of snake motions; there are several possible ways to control a snake robot. The research shows that snakes move along the surface by deforming their bodies. Typical snake motions are forward, serpentine, lateral and crawler. A snake body takes the S-shape at concertina motion; its front part moves forward while its back part constricts.

Consider in detail the typical movements of a snake to understand the laws of motion for modeling a snake robot [8-9]. A snake moves due to friction between the side surface and the ground at serpentine motion. The body bends and waves would run along the body from head to tail when the type of motion is snake-like. A bending part of the body that is set obliquely to the direction of its motion rests on the surface and creates a pushing force. This force is directed at an angle to the movement, but can be decomposed into two components: perpendicular and parallel to the line of motion. The resistance of the support dampens the first component, and the second pushes the body forward. Thus, the more bends, the more the total driving force. Almost all mobile vehicles designed by the human to use on land, are either wheel or foot driven. Wheeled vehicles started to be used several thousand years. Vehicles, which use steps to move, appeared later. Other driving mechanisms – chain tracks and feet were introduced in the twentieth century, in 1920 in particular, since then the first prototypes of snake-like robots appeared. There are various models of snake robots [10]: waver; active cord mechanisms; manipulator without support; shan; the quake snake, etc.

Nowadays, the snake-like robot “Uncle Sam snake” is the most advanced technical and software product [11]. The mentioned robot is able to climb a tree easily, crawl cross-country, and, most significantly, change from one motion mode to another in a matter of seconds. Servo engines fixed on special units are used in this snake. It allows the robot to move according to almost any algorithm, similar to the real snake motion. The robot possesses a camera taking the picture in the FullHD format (standard in accordance with matrix resolution 1920×1080 pixels), as well as a number of sensors, which make it possible to orientate. The fastest natural snakes can move with the speed 3m/s in ideal conditions. It seems unlikely that robotic systems will move with the same speed in the nearest future as the majority of snakes move rather slow. Feedback control approach is used in the Dinamixel AX-12A servo-engines, due to this high accuracy of positioning has been achieved.

2. Methodical part

Kinematics is a section of mechanics, which investigates mathematical description of idealized moving objects without considering the reasons for movement. The target of kinematics is geometry analytical description of an absolute robot motion apart from considering the forces affecting it. The problem of kinematics is analytical description of kinematic pairs spatial arrangement depending on time. An analytical mathematical robot model for kinematics problems statement and calculation is made, which is based on types and number of units; geometrical sizes of units; kinematic pairs distribution [12-13]. Each part or several parts joined in a stationary position are called a kinematic unit. Some parts are in motion during the device operation. Movable joint of two parts providing a certain movement of one part in relation to another one is called a kinematic pair [14]. A number of kinematic pairs joined to one another form a kinematic chain [15]. Kinematic chains classification is shown in Figure 1.

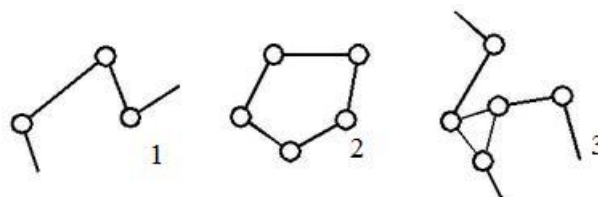

Fig. 1. Types of kinematic chains, where 1 is open kinematic chain; 2 is closed kinematic chain; 3 is complex open kinematic chain.

Now snake robot kinematics has been calculated and can be realized based on an industrial manipulator. It will be discussed further. Due to the presence of several kinematic pairs for the robot transfer, the units must move in the defined sequence.

Figure 2 shows the fixed positions of the linear robot motion phase. The snake robot is supposed to perform one “step” within time T , and then each of the intermediate state must be performed within $1/8T$. In order to ensure stability at the beginning of motion, the head and tail remain on the surface, whereas the media bend. The snake robot moves due to the unit bends, the direction of its head and tail is unchanged. In order to perform various tasks, for example, obstacle avoidance, it is necessary to change motion directions of the definite robot unit.

The consequential phases possess a number of characteristics, when the robot linearly moves on the surface. The head position is unchanged in positions 1, 2, 3 and 5, 6, 7, and the robot tail position is fixed in positions 3, 4, 5, 7, 8, 9 (Fig. 2).

We will define the relation between the transfer point O and time transfer F and time t , according to the phases of linear robot motions:

$$\{F(a, t) = x \cdot n + d_f \cdot t = n \cdot T + \tau, \tag{1}$$

$$x = 8L(1 - \cos \cos \alpha), \tag{2}$$

where x is the robot transfer within one cycle; n is number of the total cycles; d_f is robot transfer within one cycle

$$\begin{aligned} d_f = & \{2L(1 - \cos \cos(\omega\tau)), 0 \leq \tau \leq \frac{T}{8} 2L(1 - \cos \cos \alpha + 2L(1 - \cos \cos(\omega(\tau - \frac{T}{8}))), \\ \frac{T}{8} < \tau \leq & \frac{T}{4} 4L(1 - \cos \cos \alpha), \frac{T}{4} < \tau \leq \frac{T}{2} 4L(1 - \cos \cos \alpha) - 2L(1 - \cos \cos \omega(\tau - \frac{T}{2})), \\ \frac{T}{2} < \tau \leq & \frac{5T}{8} 6L(1 - \cos \cos \alpha) - 2L(1 - \cos \cos \omega(\tau - \frac{5T}{8})), \\ \frac{5T}{8} < \tau \leq & \frac{3T}{4} 4L(1 - \cos \cos \alpha), \frac{3T}{4} < \tau \leq T, \end{aligned} \tag{3}$$

where τ is time within which the transfer d_f is performed; ω is angular velocity of a robot unit.

Figure 2 shows that the robot can only move forward, which is not sufficient for a mobile robot. Changes in motion directions provide the robot with access to any point in the horizontal plane.

Figure 3 shows changes in directions of the robot motion. It is necessary to plot the time function $G(\beta)$ to change the snake robot motion direction

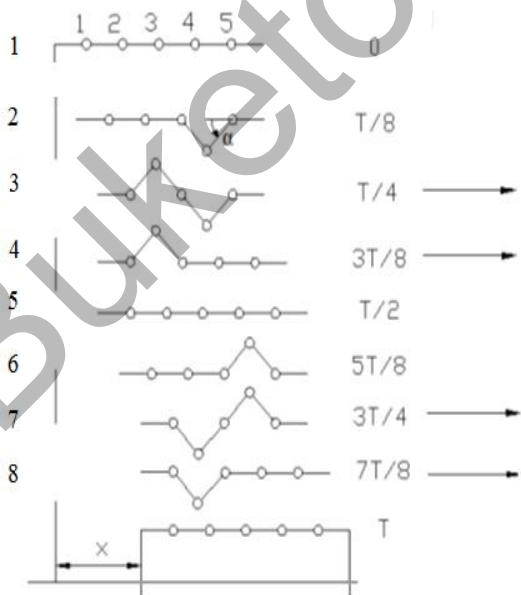

Fig. 2. Linear motion phases of the robot

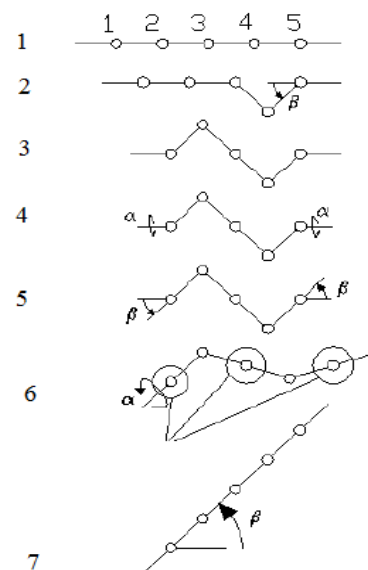

Fig. 3. Changes in the robot motion direction on the horizontal plane, where α is angle in the vertical plane; β is angle in the horizontal plane

$$G(\beta) = \sum t_i (i = 1, \dots, 6), G(\beta) = \sum t_i \quad (i = 1, \dots, 6) \quad (4)$$

where $G(\beta)$ is time needed for changes in motion direction of at an arbitrary angle β .

A robot turn by an angle $\beta = 45^\circ$ is performed within time T_H .

$$T_H = \sum_{i=1}^6 T_i, \quad (5)$$

where T_i is time for transfer from phase i to $i+1$.

If parameters α , β and t are given, the robot head position coordinates can be determined:

$$x = \cos \cos \beta_1 F(\alpha_1, t_1) + \dots + \cos \cos (\sum \beta_1) F(\alpha_1, t_i), \quad (6)$$

$$y = \sin \sin \beta_1 F(\alpha_1, t_1) + \dots + \sin \sin (\sum \beta_1) F(\alpha_1, t_i), \quad (7)$$

$$T_m = \sum t_i \sum G(\beta_i), \quad (8)$$

where T_m is time of mobile robot motion.

The robot moves due to the unit winding and can bypass obstacles; the problem of the robot body transfer from one position to another has been solved.

Thus, it is necessary to know to design a kinematic model:

- types and number of units;
- geometrical dimension of units;
- distribution of kinematic pairs;

and to solve the direct and inverse problems of the robot spatial positioning.

3. Results and discussion

Robotis Bioloid is a kit for constructing a robot. Robotis Korean firm produces it. The kit is intended for educational purposes, as well as for those interested in robotics. The kit Bioloid is similar to LEGO Mindstorms kit by the company LEGO and Vex Robotics Design System by the company VEX Robotics (Werter Technology, 2015). The kit Bioloid contains servos Dynamixel, a set of sensors, software including 3D modeling environment and programming environment in C-like language (Table 1). The number of actuators is enough to produce a mechanism with eighteen degrees of freedom.

Table 1. List of parts in ROBOTIS BIOLOID Premium Kit

Servo Dynamixel AX-12 +, pcs.	18
Two-axial gyroscope, pcs.	1
IR finder, pcs.	1
IR obstacle sensor, pcs.	2
Remote control RC-100, pcs.	1
Set of robot trunk covering, pcs.	1
Li-Po battery, pcs.	1
Charging unit, pcs.	1
CD, pcs.	1
Screwdriver, pcs.	1
Cable clamp, pcs.	1

Eighteen Robotis Dynamixel AX-12A servomotors (Robotis e-Manual, 2015) are used to perform motions. The servomotors are capable of working in the positioning mode (in this mode each servo has 1024 possible positions) and in the rotation mode.

The servomotors maintain the joint through half duplex asynchronous protocol (Avage Robotics, 2015) (used with controller CM-530), RS485. The communication between the servomotors and the operator is obtained with the help of data package exchange. The servos are connected to the operator in sequence. As a matter of convenience in designing robot models, several servo-motors lines can be connected to the operator.

It is recommended to use four lines to connect servomotors, for example, when a humanoid is constructed: one line for each extremity. A maximum number of lines available for controller CM-530 are five pieces. Robots of various structures can be assembled with the help of the Dynamixels actuators in the form of instantiated units. Construction mobility is provided due to application of joint for joining actuators to one another. A snake robot is a ground multi-unit mobile robot, which can move in the restricted space, bypass obstacles and move on the surface. It is possible to design a robot structure, having identified the number of units, are knowing their geometrical sizes and made kinematic pairs distribution. We can conclude that the snake robot is an open kinematic chain the elements of which are connected with one another by five or more rotation kinematic units, based on the solutions of the direct and inverse problems. A crawling robot structure consists of five units with the total length of 0.44 m (Fig. 4a). It can be modernized up to eighteen units, depending on its execution. The units are connected with one another with the help of joints so that the turns around horizontal axis provided for each of them. A five-unit robot could not move due to its heavy head, servos did not have enough capability for moving. The snake moved on-the-site. That is why it was decided to add six units more. An eleven-unit snake structure consists of eleven units (Fig. 4b) with the total length of 0.91 m. A snake robot moves on the smooth surface with some is sliding, therefore, rubber "footing" can be attached to the unit bottom part to ensure necessary robot traction coefficient. All possible ways of snake motions have been studied before writing the motion algorithm. As a result, the algorithm of the direct snake motion (Fig. 5a) and the algorithm of the reverse snake motion (Fig. 5b) have been written.



Fig. 4. A snake robot structure with different number units, where a is with five chains; b is with eleven units

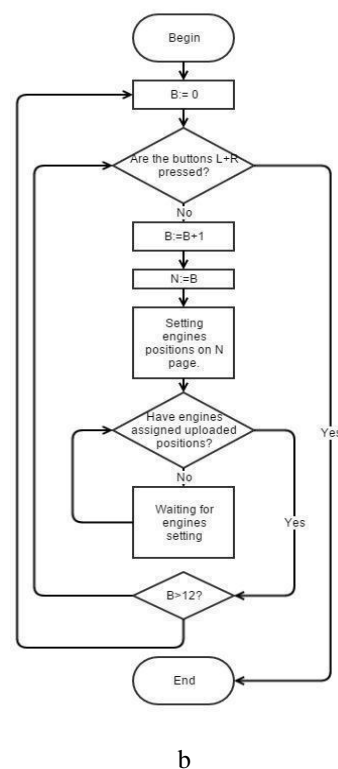
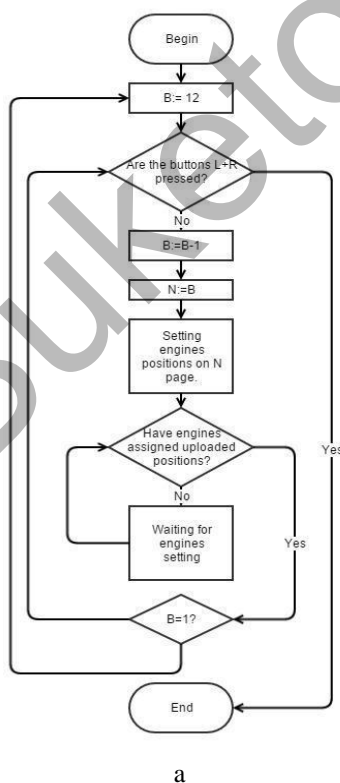

Fig.5. Algorithm of a snake robot motion, where a is direct algorithm, b is reverse algorithm.

Programming the snake-like robot designed on the basis of Bioloid Premium Kit was carried out with the help of the problem-oriented software system RoboPlus. The snake robot control program was created with the help of the programming environment RoboPlus Task as well as the programming environment RoboPlus Motion. Initially, positions of all eleven engines were selected, thereby the shape of the snake robot was comparable with the real snake when it moves. Initial position of a snake-like robot is illustrated in Figure 6a. A number of engines starts from the head and takes place towards the tail. It is shown in Figure 6b.



a

ID	Value	
ID[1]	647	<input checked="" type="checkbox"/>
ID[2]	678	<input checked="" type="checkbox"/>
ID[3]	628	<input checked="" type="checkbox"/>
ID[4]	387	<input checked="" type="checkbox"/>
ID[5]	379	<input checked="" type="checkbox"/>
ID[6]	400	<input checked="" type="checkbox"/>
ID[7]	364	<input checked="" type="checkbox"/>
ID[8]	392	<input checked="" type="checkbox"/>
ID[9]	661	<input checked="" type="checkbox"/>
ID[10]	658	<input checked="" type="checkbox"/>
ID[11]	642	<input checked="" type="checkbox"/>

b

Fig. 6. The initial position, where a is of a snake robot, b is of engines/

There is an impression that a snake does not crawl but floats like a wave when we observe moving snakes. The basis for creating this algorithm has been invented due to this observation. The position of each following engine was transmitted to the previous one. For example, number 11 engine transmits its location to number 10 engine at the first locomotion, while number 10 engine transmits its location to number 11 engine. After the last unit, the location of number 1 engine is transmitted to number 11 engine, and the cycle starts again. Eleven positions of the snake had to be created for functioning of the set algorithm; they were in-series shifted onto one position of engines relative to the previous one (Fig. 7).

Consequently, locomotion has been created which enables a snake robot repeat a real snake motion. The following characteristics have been improved after testing the snake motion algorithm: smoothness and speed of snake motions. Such parameter as Joint Softness is responsible for smoothness of engines motion (Fig. 8). The greater value Joint Softness for a certain engine is, the smoother a robot will move.

	Name	Next	Exit
1	1	0	0
2	2	0	0
3	3	0	0
4	4	0	0
5	5	0	0
6	6	0	0
7	7	0	0
8	8	0	0
9	9	0	0
10	0	0	0
11	11	0	0
12		0	0

Fig. 7. Eleven positions of the snake written in RoboPlus Motion

ID	Level
ID[1]	7
ID[2]	7
ID[3]	7
ID[4]	7
ID[5]	7
ID[6]	7
ID[7]	7
ID[8]	7
ID[9]	7
ID[10]	7
ID[11]	7

Fig. 8. The controller of engine operation smoothness

Moreover, RoboPlus Motion programme software makes it possible to set a quantity of motion repeats, speed of engine work, as well as inertial force after finishing engines operation (Figure 9). It was necessary to fully assemble all parts of the program after setting all possible parameters of engines. In order to do it, the

RoboPlus Task programme software was applied. C-like language, intended for the work with Bioloid products was used in the programming environment. It is necessary to download the program onto the inner memory of the robot with the help of the "Download Program" button after writing the software code (Fig. 10). Motion algorithms were tested on eleven various surfaces.



Fig. 9. Form for changing speed of engine work

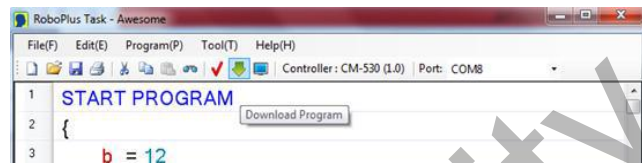

Fig. 10. Uploading files on the inner memory controller in the programming environment RoboPlus Task

The main point of tests was indicating the most favorable surfaces for prototype movement by measuring the motion speed of a snake robot. The length of the snake-like robot assembled on the basis of Bioloid premium kit which includes eleven units being stretched is 88 cm. Tests involved accomplishing the given distance, i.e. a distance was considered covered at the moment when the snake tail crossed the initial position of its head. Ten experiments have been conducted on each surface; the overall average has been calculated. The most common surfaces were selected such as paving slab, asphalt, linoleum, plastic, ground, carpeted floor and grass. Results of all experiments of eleven various surfaces were obtained and results of one experiment is presented below as example.

The snake moved on asphalt with approximately the same speed as that on paving slab (Fig. 11). Data about the time spent on accomplishing the distance are presented in Table 2.



a



b

Fig. 11. Position of the snake robot, where a is an initial position, b is a final position

The following is a comparative analysis of the robot under study with other existing robots of this type.

Since 1920, the first prototypes of serpentine robots began to appear. The first prototype of the snake-like robot was presented by Peter Míturich, who developed a number of designs called "Waveguides". Nine technical ways of solving the principle of undulating motion on the earth were proposed. In 1970, a legless robot "Active Cord Mechanisms or ACMs" was built. It was aimed at performing a lateral type of movement and moved due to the existing wheelbase. At the beginning of the XXI century, Joel Burdick and his students from the California Institute of Technology developed a VGT manipulator that could repeat the movements of snakes. Later, the Shan robot was developed, which differed from the others in that it used solenoids to contact the surface, which allowed at a certain moment to fix the desired part of the snake on the surface,

while the rest of the snake was moving. Due to the configuration, the robot's movement was limited on a flat floor and with a tortuous type of movement when a large space is required.

Table 2. Timed consumed for movement on asphalt

Experiment number	Surface used	Operating time, sec	Average value, sec
1	asphalt	58	63
2		65	
3		68	
4		60	
5		57	
6		63	
7		69	
8		66	
9		72	
10		55	

The giant Japanese electronics company NEC has developed a robot snake "The Quake Snake". The device used a universal Hook joint, which was designed specifically for use in the construction of a snake robot. This snake-like robot is not a promising because of such a hinge, the design turned out to be very flexible and versatile. The robot was controlled manually by means of a special remote control and a video camera.

GMD snake was developed by a working group working in Germany: the serpentine robot was a development for real-time control. The device consisted of short sections connected by cables.

IS robotics has built a small Kaa snake designed for grabbing pipes, branches, etc., as well as for moving along the surface with a tortuous type of movement. The robot was not the most effective in terms of wriggling crawling on the floor due to the large processor unit located in the middle of the robot. The "Kaa snake" managed to move more efficiently in the pipeline networks. It was the first fully autonomous snake robot. Comparative analysis has shown that the presented project uses lateral movement, which distinguishes our development from most other developments of snake robots. According to the presented hypothesis, which was later confirmed experimentally, the snake robot demonstrates the best speed with lateral movement on moderately fleecy surfaces.

4. Conclusion

Algorithm, based on the studying the physical characteristics of the snake robot movement, which takes into account the interaction and position of neighboring links of the snake robot, was created and it ensures the smooth of the snake robot movement. Test results showed that it is possible to control the robot's movement on seven different types of surfaces thanks to this algorithm. The advantage of this development compared to other analogues is to ensure smooth movement of the snake robot on various surfaces, in particular, with moderate hairiness, while most such robots move using a worm-like method or jerks. In addition, the required minimum (eleven) positions of the snake was studied for the functioning of the given algorithm with using the created robot system with motors sequentially shifted by one position relative to the previous one and transmitting the position of each subsequent motor to the previous one. Thus, a hardware and software complex was obtained that simulates also the lateral movements of sand snakes with the best movement performance on moderately fleecy surfaces. Now it has become possible to control the movement of robots of this type when using them in different life situations in various fields of application, using the developed algorithm for the movement of a snake robot. An experimental snake robot powered by DYNAMIXEL motors, in the presence of a protective casing, can be used in the field of extreme robotics in conditions where it is difficult for a person to stay: for example, in a situation with bad weather conditions or in an aggressive environment inaccessible to humans.

REFERENCES

1 Kesteloo T.V. Autonomous navigation for the pipeline inspection robot "Pirate". 2020. Available at: http://essay.utwente.nl/85373/1/85373_Kesteloo_MA_EEMCS.pdf

- 2 Borikov V.N., Galtseva O.V., Filippov G.A. Method of Non-contact Calibration of the Robotic Ultrasonic Tomograph. *IOP Conference Series: Materials Science and Engineering*, 2016, Vol. 671, 012014. doi: 10.1088/1742-6596/671/1/012014.
- 3 Trebuña F., Virgala I., Pástor M., Lipták T. Miková L. An inspection of pipe by snake robot. *International Journal of Advanced Robotic Systems*, 2016. Vol. 13, No. 5. doi: 10.1177/1729881416663668.
- 4 Runciman M., Darzi A., Mylonas G.P. Soft Robotics in Minimally Invasive Surgery. *Soft Robot*, 2019, Vol. 6, No. 4, pp. 423–443. doi: 10.1089/soro.2018.0136.
- 5 NASA shows a snake robot to explore planets. 2023. Available at: <https://universemagazine.com/en/nasa-shows-a-snake-robot-to-explore-planets-video/>
- 6 Sanfilippo F., Azpiazu J., Marafioti G., Transeth A.A., Stavadahl Ø., Liljebäck P. Perception-Driven Obstacle-Aided Locomotion for Snake Robots: The State of the Art, Challenges and Possibilities †. *Applied Sciences*, 2017, Vol. 7, No. 4, 336. doi: 10.3390/app7040336.
- 7 Matthews T. *Do Snakes Have Bones?* Information and Facts, 2021. Available at: <https://pestsamurai.com/do-snakes-have-bones/>
- 8 Ali Sh. *Newton-Euler approach for bio-robotics locomotion dynamics: from discrete to continuous systems*. Automatic. France: Ecole des Mines de Nantes, 2011, 251 p.
- 9 Rollinson D. *Control and Design of Snake Robots*. Pennsylvania: Carnegie Mellon University, 2014, 203 p.
- 10 Zhang J., Chen Y., Liu Y., Gong Y. Dynamic Modeling of Underwater Snake Robot by Hybrid Rigid-Soft Actuation. *Journal of Marine Science and Engineering*, 2022. Vol. 10, No. 12, 1914. doi: 10.3390/jmse10121914.
- 11 Wright C., Buchan A., Brown B., Geist J., Schwerin M., Rollinson D., Tesch M., Choset H. Design and architecture of the unified modular snake robot. *Proceedings of the 2012 IEEE International Conference on Robotics and Automation*, 2012, 4347. doi:10.1109/ICRA.2012.6225255.
- 12 Shumilin N.A., etc. Kinetic robot programming. *Proceedings of the 2014 All-Russian Scientific and Technical Conference "TUSUR Scientific Session"*, 2014, pp. 155–157. https://storage.tusur.ru/files/43235/2014_3.pdf [in Russian]
- 13 Iurevich E.I. *Basics of Robotics*. Sankt-Peterburg: BKhV-Peterburg, 2010, 252 p. [in Russian]
- 14 Frolov K.V., Vorobev E.I. *Industrial Robot Mechanics*. Moskva: Vysshaya shkola, 1989. 383 p. [in Russian]
- 15 Chang K.H. *Chapter 8-Motion Analysis*. Academic Press, 2015, pp. 391–462. doi: 10.1016/B978-0-12-382038-9.00008-9.

Article received 12.10.2023

Article accepted 05.11.2023